

# Wills Rings®



**Your Partner for Sealing Technology**



## Your Partner for Sealing Technology

Trelleborg Sealing Solutions is a major international sealing force, uniquely placed to offer dedicated design and development from our market-leading product and material portfolio: a one-stop-shop providing the best in elastomer, thermoplastic, PTFE and composite technologies for applications in aerospace, industrial and automotive industries.

With 50 years of experience, Trelleborg Sealing Solutions engineers support customers with design, prototyping, production, test and installation using state-of-the-art design tools. An international network of over 70 facilities worldwide includes over 20 manufacturing sites, strategically-positioned research and development centers, including materials and development laboratories and locations specializing in design and applications.

Developing and formulating materials in-house, we utilize the resource of our material database, including over 2,000 proprietary compounds and a range of unique products.

Trelleborg Sealing Solutions fulfills challenging service requirements, supplying standard parts in volume or a single custom-manufactured component, through our integrated logistical support, which effectively delivers over 40,000 sealing products to customers worldwide.

Facilities are certified to ISO 9001:2008 and ISO/TS 16949:2009. Trelleborg Sealing Solutions is backed by the experiences and resources of one of the world's foremost experts in polymer technology: the Trelleborg Group.

ISO 9001:2008

ISO/TS 16949:2009

The information in this brochure is intended to be for general reference purposes only and is not intended to be a specific recommendation for any individual application. The application limits for pressure, temperature, speed and media given are maximum values determined in laboratory conditions. In application, due to the interaction of operating parameters, maximum values may not be achieved. It is vital therefore, that customers satisfy themselves as to the suitability of product and material for each of their individual applications. Any reliance on information is therefore at the user's own risk. In no event will Trelleborg Sealing Solutions be liable for any loss, damage, claim or expense directly or indirectly arising or resulting from the use of any information provided in this brochure. While every effort is made to ensure the accuracy of information contained herewith, Trelleborg Sealing Solutions cannot warrant the accuracy or completeness of information.

**To obtain the best recommendation for a specific application, please contact your local Trelleborg Sealing Solutions marketing company.**

This edition supersedes all previous brochures.  
This brochure or any part of it may not be reproduced without permission.

© All trademarks are the property of Trelleborg Group.  
The turquoise color is a registered trademark of Trelleborg Group.  
© 2012, Trelleborg Group. All rights reserved.



**Contents**

Introduction ..... 3

Method of Operation ..... 4

Selection Table ..... 5

Materials ..... 6

Hardware, Finish and Media ..... 8

Wills Rings® O..... 9

Wills Rings® C ..... 11

Wills Rings® O and C / Special Designs For Non-Circular Grooves..... 12

Compression Loads to Seat Wills Rings® ..... 13

Calculating Seating Loads ..... 14

Groove Designs..... 16

Part Numbers and Ordering Instructions in Metric ..... 18

    Installation Recommendations for Internal Pressure Sealing ..... 18

    Installation Recommendations for External Pressure Sealing..... 21

Metric Part Numbers and Ordering Instructions..... 24

    Metric Size Ranges and Free Heights ..... 24

    Metric Groove Clearance and Plating Allowances..... 25

    Metric Part Number Systems for Wills Rings® ..... 26

Inch Part Numbers and Ordering Instructions..... 28

    Inch Size Ranges and Free Heights ..... 28

    Inch Groove Clearance and Plating Allowances ..... 29

    Inch Part Number Systems for Wills Rings® ..... 30

Quality Criteria ..... 32

Storage ..... 32

Conversion Tables ..... 34

Technical Questionnaire ..... 35

Digital Services ..... 36





## ■ Introduction

Trelleborg Sealing Solutions designs and manufactures a wide range of seals and bearings, which are used in many industries and applications, including Wills Rings®. Wills Rings® are the original metal O-Ring seals. First developed at the Trelleborg Sealing Solutions facility in Bridgwater, the term Wills Rings® has become synonymous with this type of seal and is internationally used as a generic term to describe metal O-Ring seals.

Superior controlled compression type seals used in static applications, Wills Rings® withstand extreme conditions that exceed the capabilities of elastomer and polymer seals. The seals are constructed from high quality metal tubing or strip in standard or thin wall thickness and are often coated or plated with a softer material to increase their sealing performance.

Wills Rings® are available in two designs and five types, see Figure 1. The designs are:

- 1) Wills Rings® O
- 2) Wills Rings® C

Wills Rings® O consist of a tube formed into a circular profile.

Wills Rings® C are similar to Wills Rings® O but with an open 'C' cross section. The open slot of the Wills Rings® C faces toward the system pressure and allows the seal to be pressure activated.

### Typical applications for Wills Rings®:

- Nuclear power plants
- Furnaces
- Offshore and marine installations
- Cryogenic situations
- Ultra-high vacuum systems
- Fire safe valves
- Plastic processing plants
- High-performance vehicles

Wills Rings® can be customized to suit the specific requirements of a system. Contact your local Trelleborg Sealing Solutions marketing company for more information.

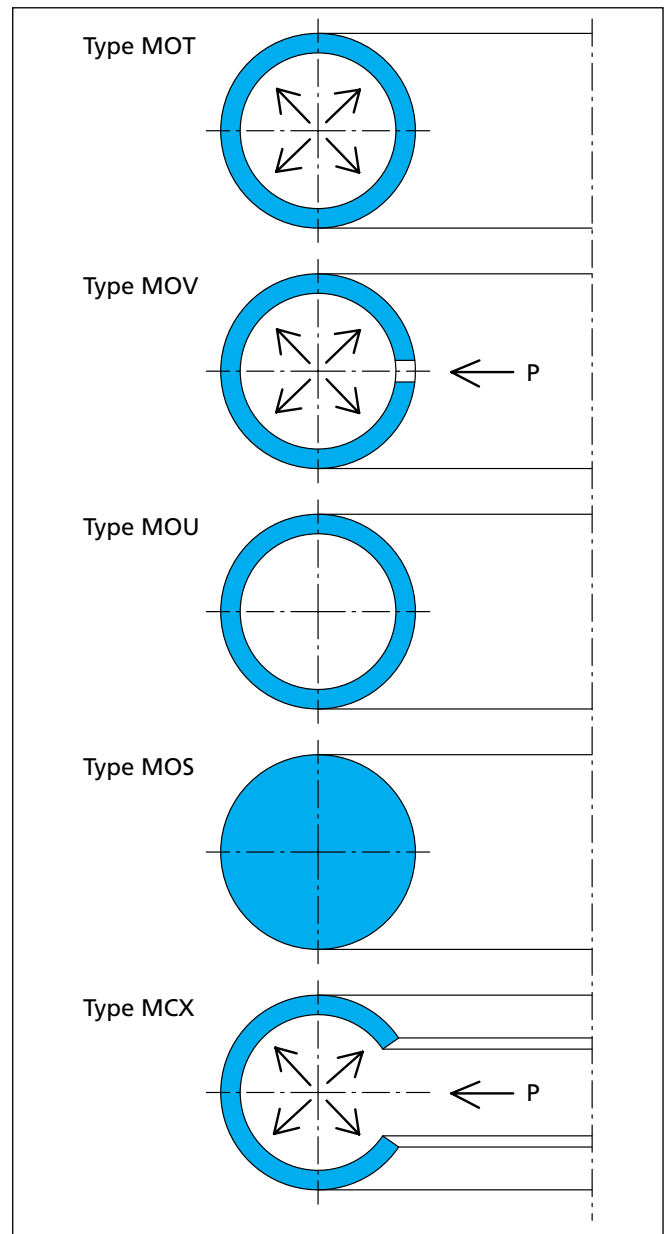

Figure 1 Wills Rings® variations



## Method of Operation

Wills Rings® consist of a metal ring, often coated, which is used as a deformable seal in a static sealing situation. The ring is located between two flanges and undergoes a controlled compression.

Wills Rings® are defined by their free height, which is the cross section in the axial direction of the seal (Figure 2). The free height  $d_2$  of the seal is compressed down to the groove depth  $h$ .

The resistance of the ring to compression enables it to generate a sealing force when compressed. The resilient effect of the seal can be increased by pressurizing the internal volume of the ring, see Type MOT gas filled Wills Rings® O.

Alternatively, if the system to be sealed is very high pressure, this system pressure can be used to provide additional sealing effect. This is called system actuation and is achieved by allowing the high pressure to enter the seal through vent holes, see Type MOV or the open C slot, Type MCX.

Wills Rings® have a certain degree of elasticity. This is known as springback. The springback is the elastic part of the seal deflection when it is installed in a groove. This dictates the seal's ability to absorb or compensate for hardware variations due to temperature or pressure loadings, maintaining the seal integrity (Figure 2).

A softer plating or coating material can be applied to Wills Rings® to maximize sealing performance in demanding applications. The coating material yields during the ring compression and fills surface machining marks (Figure 3).

For best sealing results Wills Rings® should be replaced each time the groove housing is dismantled as the plating or coating material deforms from use and performance can't be guaranteed again once the housing has been dismantled.

### Performance

Because Wills Rings® are constructed from metal, their ability to handle extreme conditions exceeds that of polymeric and elastomeric seal types.

Unlike elastomer seals, Wills Rings® are not subject to outgassing making them suitable for use on equipment sensitive to outgassing.

### Features and benefits

- Temperature range from cryogenic to 850 °C / 1,550 °F
- Pressure range from ultra-high vacuum to 1,000 MPa / 145,000 psi
- Compatible with a large range of media
- Corrosion resistant and radiation tolerant
- Simple and reliable sealing
- No outgassing
- Immune to explosive decompression
- Wide range of sizes

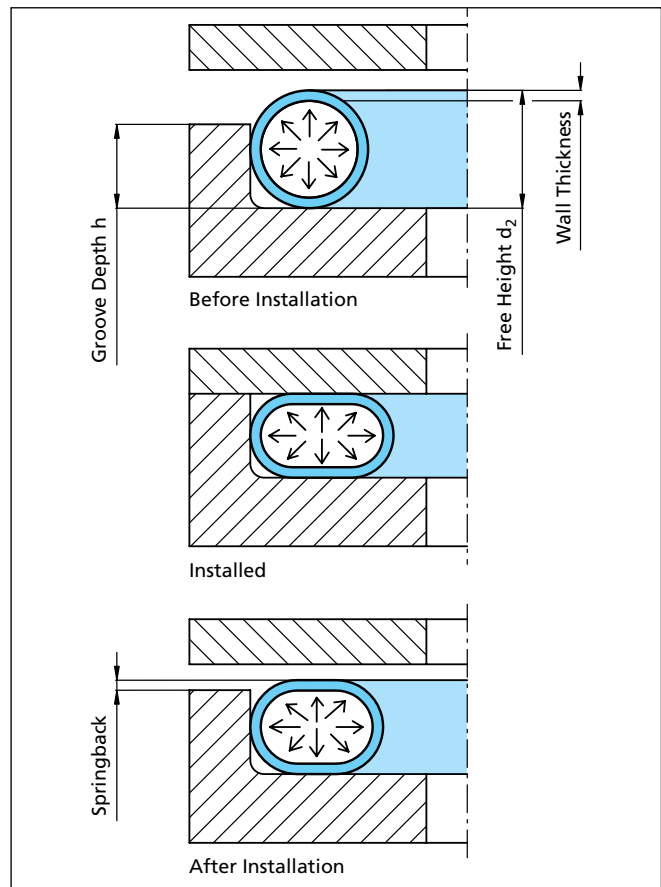

Figure 2 Method of seal operation

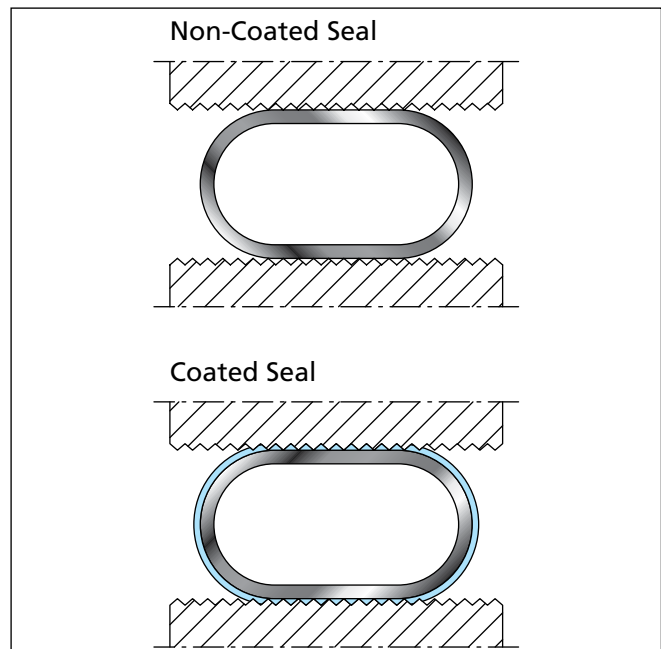

Figure 3 Contact surface for coated and non-coated Wills Rings®









## ■ Selection Table

Use this table to select the optimum seal for an application.  
A, B, C or D indicates relative performance.

Further information can be found on the relevant pages  
as indicated.

**Table 1 Selection Criteria**

If further information on seal selection is required please contact your local Trelleborg Sealing Solutions Marketing Company. Inconel® is a trademark of INCO Alloys International, Inc.

Seal			Extreme Conditions	Seating Loads	Spring-back	Vacuum Sealing	Pressure MPa/psi	Max. Working Temp. °C / °F	Standard Material	
Code	Page								Seal	Coating
 Type MOT	9	Pres-surized	A	C	C	1x10 <sup>-9</sup> mbar.l.s. <sup>-1</sup>	40 MPa 5,800 psi	850 °C 1,550 °F	Mild steel Stainless Steel 316 L Stainless Steel 321 Inconel® 600 Inconel® 718 Copper	Silver Nickel Copper Gold Indium
 Type MOV	9	Vented internal	B	B	C	-	1,000 MPa 145,000 psi	600 °C 1,100 °F		
 Type MOW	9	Vented external								
 Type MOU	10	Non-Pres-surized	C	B	C	1x10 <sup>-5</sup> mbar.l.s. <sup>-1</sup>	4 MPa 580 psi	400 °C 750 °F		
 Type MOS	10	Solid	C	D	D	1x10 <sup>-5</sup> mbar.l.s. <sup>-1</sup>	4 MPa 580 psi	500 °C 925 °F		
 Type MCX	12	Internal pressure	B	A	A	1x10 <sup>-7</sup> mbar.l.s. <sup>-1</sup>	200 MPa 29,000 psi	750 °C 1,375 °F		
 Type MCY	12	External pressure								

Properties: A = Excellent B = Good C = Satisfactory D = Poor



## ■ Materials

### Seal Material

Available in a wide range of materials, Wills Rings® are used as static seals in a large number of industrial sectors. The choice of material affects the seal performance and materials should be chosen after considering the following requirements:

- Pressure and temperature
- Seating loads
- Corrosion resistance
- Compatibility with housing materials
- Length of life
- Sealing level
- Cost

### Industry Standards

For some industries seal material selection can be critical and require compliance with industry standards.

For example, a Wills Rings® O or C with compliance to NACE MR0175 should be selected in material Inconel® 718 and be hardened using treatment 5 as shown in the part number tables.

**Table 2 Standard Seal Materials for Wills Rings® O**

Standard Material	Maximum Operating Temperature		Code
	°C	°F	
Copper	400	750	O
Mild steel	550	1,025	B
Stainless Steel AISI 316L (1.4435)	800	1,475	H
Stainless Steel AISI 321 (1.4541)	800	1,475	E
Inconel® 600	850	1,550	M
Inconel® 718	850	1,550	L

**Table 3 Standard Seal Materials for Wills Rings® C**

Standard Material	Maximum Operating Temperature		Code
	°C	°F	
Inconel® X750 (Jacket)	750	1,375	N
Inconel® 718 (Jacket)	750	1,375	L

Please note:

Not all materials are available in all sizes.

Alternative jacket, spring and coating materials can be offered. Please contact your local Trelleborg Sealing Solutions Marketing Company for details.





## Plating and Coating Materials for Wills Rings®

The sealing capability of Wills Rings® is greatly enhanced by the addition of a softer coating material, see Figure 3. Table 4 gives the technical data for each coating, including the plating thickness, temperature capability and the size range.

Select plating and coatings for applications by considering the following system requirements:

1. Level of sealing needed and the fluid to be sealed
2. Operating temperature
3. Compatibility to media

For higher levels of sealing, more layers of plating should be combined with a better surface finish.

**Note:**

Increased plating and a better surface finish make the seal and the hardware more expensive to produce.

For less critical applications non-plated rings may provide sufficient sealing.

Contact your Trelleborg Sealing Solutions Marketing Company for further information

**Table 4 Standard Coating Materials**

Coating		Coating-Thickness		Temperature		Comments	Max. Ø	
Material	Code	mm	inch	°C	°F		mm	inch
Nickel	Q	0.030 ± 0.005	0.0012 ± 0.0002	1,200	2,200	-	1,000	39
Silver	R	0.030 ± 0.005	0.0012 ± 0.0002	800	1,475	1 layer silver	1,000	39
Silver	U	0.055 ± 0.005	0.0022 ± 0.0002	800	1,475	2 layers silver	1,000	39
Silver	S	0.080 ± 0.005	0.0031 ± 0.0002	800	1,475	3 layers silver	1,000	39
Gold	I	0.030 ± 0.005	0.0012 ± 0.0002	930	1,706	-	1,000	39
Copper	O	0.030 ± 0.005	0.0012 ± 0.0002	930	1,706	-	1,000	39

**Note:**

Other non-standard plating/coating options are available.



## ■ Hardware, Finish and Media

Table 5 shows the media that can be sealed with different plating materials and the required surface finish for the housing. It is important that all machining marks are concentric with the line of seal contact. Spiral or radial marks should be avoided as these can form leak paths across the seal face.

The groove should be machined to the required finish and not polished by hand. Polishing can lead to radial marks on the sealing surface which may form leak paths.

Typically a thin gas is more difficult to seal than a heavy liquid, and requires a better surface finish. The lower the media viscosity, the higher the surface finish quality and plating level required.

**Table 5 Media and Hardware Surface Finishes**

Sealing System/Media	Ra		R <sub>max</sub>		Typical Coating	Comments
	μ m	μ inch	μ m	μ inch		
Ultra-high vacuum	0.1 - 0.2	4 - 8	1.2 - 1.6	48 - 64	S	Use this for safety critical systems
Cryogenic - High vacuum	0.1 - 0.2	4 - 8	1.2 - 1.6	48 - 64	S	
Helium, Hydrogen	0.1 - 0.2	4 - 8	1.2 - 1.6	48 - 64	S	
Nitrogen, Steam	0.2 - 0.4	8 - 16	2.0 - 2.5	80 - 100	R/S/Q	-
Cryogenic - Light vacuum	0.2 - 0.4	8 - 16	2.0 - 2.5	80 - 100	R/S/Q	-
Air, Water, Light fuel	0.4 - 0.8	16 - 32	3.0 - 4.0	120 - 160	R/Q	Non-plated rings may be suitable
Heavy oils, Polymer	0.4 - 0.8	16 - 32	3.0 - 4.0	120 - 160	R/Q	



**Wills Rings® O  
Type MOT (Gas Filled)**

The most frequently used Wills Rings® are filled with nitrogen gas. The gas pressure inside the seal rises with temperature to offset the loss of tubing strength at elevated temperatures.

**Advantages**

- High temperature capability
- Available in a wide range of materials and finishes
- Resistant to corrosion, chemical attack and radiation
- Long Life
- Resilient (springback)

**Technical Data**

Operating Pressure: Vacuum - helium tight  
 $1 \times 10^{-9}$  mbar.l.s<sup>-1</sup>  
 up to 40 MPa / 5,800 psi

Temperature: Cryogenic to 850 °C / 1,550 °F  
 (constant temperature)

Seal Type: Internal and external sealing pressure

Standard Materials: Stainless Steel

Coating Materials: Gold  
 Indium  
 Copper  
 Nickel  
 Silver

**Note:**  
 Other non-standard plating/coating options are available.

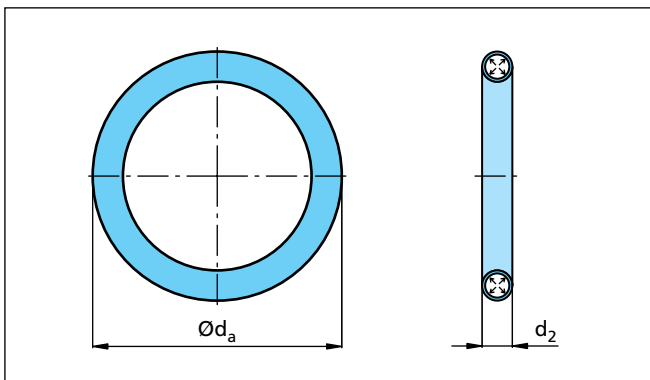

Figure 4 Wills Rings® O - Type MOT

**Wills Rings® O  
Type MOV Internal Pressure  
Type MOW External Pressure  
(System Pressure Actuated)**

These seals are ideal for extreme pressure applications. System pressure actuates the seal ring through vent holes on the seal wall. The vent holes are on the inside diameter for internal pressure (Type MOV), and on the outside diameter for external pressure (Type MOW).

These vent holes enable the internal pressure of the seal to equal the system pressure.

**Advantages**

- High pressure capability
- Available in a wide range of materials and finishes
- Resistant to corrosion, chemical attack and radiation
- Long life

**Technical Data**

Operating Pressure: 7 to 1,000 MPa /  
 1,015 to 145,000 psi

Temperature: Cryogenic to 600 °C / 1,100 °F  
 (constant temperature)

Seal Type: Internal and external pressure sealing

Standard Materials: Stainless Steel

Coating Materials: Gold  
 Indium  
 Copper  
 Nickel  
 Silver

**Note:**  
 Other non-standard plating/coating options are available.

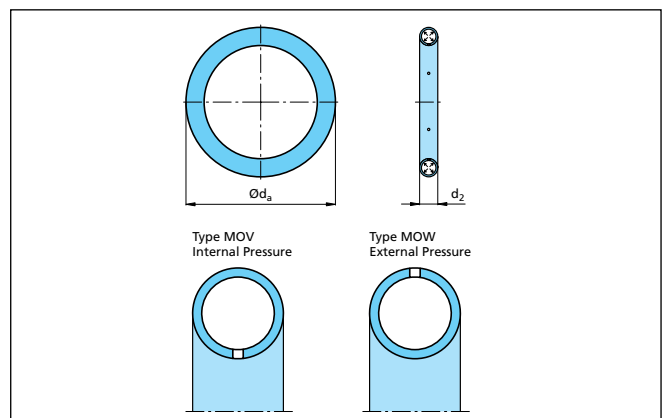

Figure 5 Wills Rings® O - Type MOV internal vented / MOW external vented



## ■ Wills Rings® O Type MOU Non-Pressurized

As these types of Wills Rings® O are filled at atmospheric pressure only, they are suitable for moderate sealing. This limits the safe maximum working temperature.

### Advantages

- Available in a wide range of materials and finishes
- Resistant to corrosion, chemical attack and radiation
- Long life
- Cost-effective in less demanding applications

### Technical Data

Operating Pressure: Vacuum - bubble tight  
 $1 \times 10^{-5}$  mbar.l.s<sup>-1</sup>  
Pressure - up to 4 MPa / 580 psi

Temperature: Cryogenic to 400 °C / 750 °F

Seal Type: Internal and external pressure sealing

Standard Materials: Stainless Steel

Coating Materials: Gold  
Indium  
Copper  
Nickel  
Silver

**Note:**  
Other non-standard plating/coating options are available.

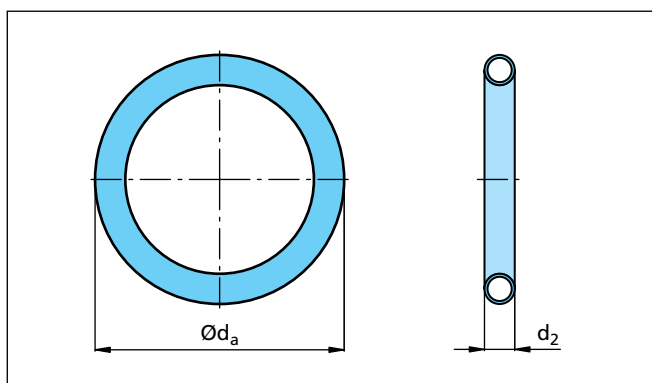

Figure 6 Wills Rings® O - Type MOU

## ■ Wills Rings® O Type MOS Solid

Solid seals exhibit virtually no elastic behavior and also have very high seating loads. Being crush seals, solid Wills Rings® O operate in a similar manner to gaskets.

### Advantages

- Good vacuum sealing capability
- Available in a wide range of materials and finishes
- Resistant to corrosion, chemical attack and radiation
- Long life
- Cost-effective in less demanding applications

### Technical Data

Operating Pressure: Vacuum - bubble tight  
 $1 \times 10^{-5}$  mbar.l.s<sup>-1</sup>  
Pressure - up to 4 MPa / 580 psi

Temperature: Cryogenic to 500 °C / 925 °F

Seal Type: Internal and external pressure sealing

Standard Materials: Stainless Steel

Coating Materials: Gold  
Indium  
Copper  
Nickel  
Silver

**Note:**  
Other non-standard plating/coating options are available.

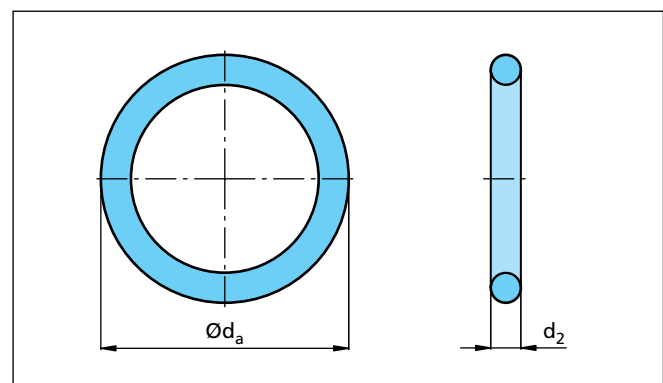

Figure 7 Wills Rings® O - Type MOS



**Wills Rings® C**  
**Type MCX Internal Pressure**  
**Type MCY External Pressure**

System pressure actuates the seal through a vent slot in the C profile which runs around the entire circumference of the seal. This slot is internal for internal pressure, and external for external pressure.

A key benefit of this seal type is an increased amount of seal springback. This can be triple the amount exhibited by metal O-Ring seals. Also, by using a thin wall section, low seating loads can be achieved.

**Advantages**

- Low seating loads
- High springback
- Good pressure and temperature capability
- Long life
- Resistant to corrosion, chemical attack and radiation

**Technical Data**

Pressure:	Vacuum - bubble tight $5 \times 10^{-7}$ mbar.l.s <sup>-1</sup> to 200 MPa / 29,000 psi
Temperature:	Cryogenic to 750 °C / 1,375 °F
Seal type:	Internal and external pressure sealing
Seal materials:	Inconel® X750 Inconel® 718
Coating materials:	Gold Indium Copper Nickel Silver

**Note:**

For internal pressure, Wills Rings® C type MCX are sized to their outside diameter, Ø da.

For external pressure, Wills Rings® C type MCY are sized to their inside diameter, Ø di.

Other non-standard plating/coating options are available.

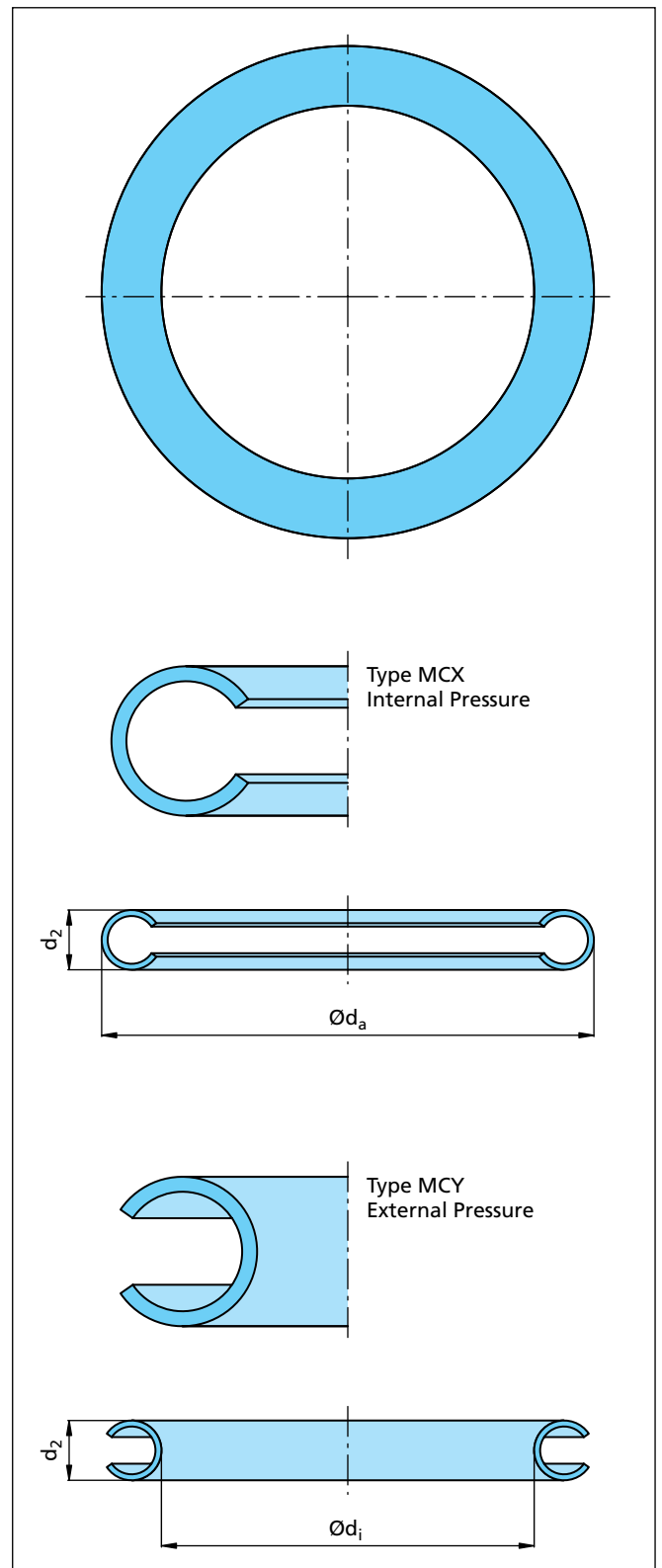

Figure 8 Wills Rings® C - Type MCX / MCY



## ■ Wills Rings® O and C Special Designs For Non-Circular Grooves

Wills Rings® can be supplied in a variety of specially manufactured shapes to accommodate non-circular flanges and vessels. When designing this type of seal the minimum bending radius in relation to the free height must be observed, see Table 6, as opposed to the minimum seal diameter for a given seal free height.

For further information on special seal designs please contact your local Trelleborg Sealing Solutions Marketing Company.

**Table 6 Minimum Bending Radius**

Free Height d2		Minimum Bending Radius	
mm	inch	mm	inch
1.59	0.063	7	0.276
2.38	0.094	13	0.500
3.18	0.125	30	1.181
3.97	0.156	50	2.000
4.76	0.187	75	3.000
6.35	0.250	100	4.000
7.94 *	0.313	200	8.000
9.53 *	0.375	300	12.000

\* Not available in Wills Rings® C



Figure 9 Example of a non-circular seal



## ■ Compression Loads to Seat Wills Rings®

Seating the seal is the process of compressing it to the correct depth, such that it forms an effective seal.

When Wills Rings® are located in a housing, a specific load must be applied to the flanges to seat the seals correctly.

The required seating load must be calculated for each seal and must be exceeded by the system load used to secure the sealing flanges together. The system pressure for internal pressure systems also has an effect on the clamping forces. This pressure acts on an area inside the seal diameter causing an extra load on the clamping system.

Minimum seating load required:

$$LT = L1 + L2$$

Where LT = Total required seating load

L1 = Load to seat seal

L2 = Load caused by internal system pressure

The securing system must be sufficiently strong to withstand the pressure and temperature effects during system operation. Most Wills Rings® are available in standard and thin wall sections. Generally, standard wall seals should be used wherever possible. A standard wall thickness ring is stronger and forms a more effective seal. A thin wall seal should be used to provide lower seating loads if required.

### Factors affecting the system design and the seating load of a seal are:

- Loss of bolt strength at elevated temperatures
- Increases in pressure at elevated temperatures
- Creep losses/relaxation over time
- The bolt loads holding the system must be sufficient to seat Wills Rings® and withstand the system pressure
- The system flanges must be strong enough to avoid deformation

#### Note:

Wills Rings® C can be hardened to modify the seal resilience. The seating load figures given in Table 10 are for standard treatment seals only (Code Number 2 - short cycle age-hardened). If a non-standard seal treatment is used, see Table 7 for options, then the correct material factor must be used in the seating load calculation, see Table 8 and 9.

All figures given for seating loads are typical values only.

It is recommended that seal users apply an appropriate safety margin in all calculations for the seating loads relative to the sealing requirements.

Tests should be conducted to establish suitability of the clamping system.

**Table 7 Wills Rings® C**

Code	Treatment
1	Work-harden
2	Age-harden (short cycle)
3	Age-harden (long cycle)
4	Solution anneal and age-harden
5	Heat treat to NACE MR0175

### Hardness/Seal Resilience

Age-hardened Wills Rings® C have higher seal resilience. This is required for silver coated Wills Rings® C in order to apply sufficient seating force to deform the coating.

Age-hardening (short cycle) is adequate for normal sealing.

Age-hardening (long cycle) can be used to provide higher seating loads offering greater seal resilience which assists with sealing in extreme conditions.

The hardness treatment code **must** be included in the Wills Rings® C part numbers. See the ordering example on page 27.

Heat treatment to NACE MR0175 can also be specified for Wills Rings® O in material Inconel® 718, using the material code 5.



## ■ Calculating Seating Loads

The compressive load required to correctly seat specific Wills Rings® in the recommended groove depends on the seal diameter, seal free height, wall thickness and seal material according to the following expression:

$$L1 = M \times K \times Dm \times \varpi$$

where L1 = Load to seat the seal (N)

M = Material factor (see Table 8 or Table 9)

K = Load in N/mm seal circumference  
(see Table 10)

D<sub>m</sub> = Median (sealing) diameter of the seal,  
da - d2 (mm)

ϖ = Pythagoras constant (3.142)

**Table 8 Material Factor Wills Rings® O**

Material Factor	M
Stainless steel AISI 316L (1.4435)	1.00
Stainless steel AISI 321 (1.4541)	1.00
Inconel® 600	1.10
Inconel® 718	1.10
Mild steel	0.75
Copper	0.75

**Table 9 Material Factor Wills Rings® C Condition**

Material Factor	M
Inconel® X750	0.85
Inconel® 718	1.00

**Note:**

Use M x 0.75 for work harden

Use M x 1.20 for age-harden (long cycle)

**Table 10 Compressive Load for Standard Wall Wills Rings®**

Cross Section			Size Code	Wills Rings® O				Wills Rings® C			
mm	inch			Wall Thickness		Seating Load Circumference		Wall Thickness		Seating Load Circumference	
mm	inch			mm	inch	N/mm	lb/inch	mm	inch	N/mm	lb/inch
0.89	0.035	thin	J	0.15	0.006	100	571	-		-	-
1.59	0.063	std	A	0.36	0.014	161	919	0.25	0.010	51	291
		thin	K	0.15	0.010	98	560	0.15	0.006	15	86
2.38	0.094	std	B	0.46	0.018	198	1131	0.38	0.015	69	394
		thin	L	0.25	0.010	52	297	0.25	0.010	28	160
3.18	0.125	std	C	0.51	0.020	176	1,005	0.51	0.020	100	571
		thin	M	0.25	0.010	65	371	0.38	0.015	62	354
3.97	0.156	std	D	0.64	0.025	253	1,445	0.61	0.024	111	634
		thin	N	0.25	0.010	46	263	0.41	0.016	46	263
4.76	0.187	std	E	0.81	0.032	280	1,599	0.76	0.030	141	805
		thin	O	0.25	0.010	37	212	0.51	0.020	63	360
6.35	0.250	std	F	1.02	0.040	100	571	-	-	-	-
		thin	P	0.51	0.020	52	297	0.64	0.025	66	377
7.94	0.313	std	G	1.27	0.050	330	1,884	-	-	-	-
9.53	0.375	std	H	1.52	0.060	380	2,170	-	-	-	-
		thin	R	0.51	0.020	85	485	-	-	-	-





The compressive load required to correctly seat specific Wills Rings® in the recommended groove depends on the seal type, seal diameter, free height, wall thickness and seal material, as described on the previous page.

diameter. Typically standard wall Wills Rings® O will require twice the seating load of standard wall Wills Rings® C.

Figure 10 is a graph showing how seal types compare to each other for a given seal cross section, wall thickness and

Table 10 on the previous page gives typical seating loads for each type and cross section of Wills Rings® and the graph below demonstrates how these measurements are taken.

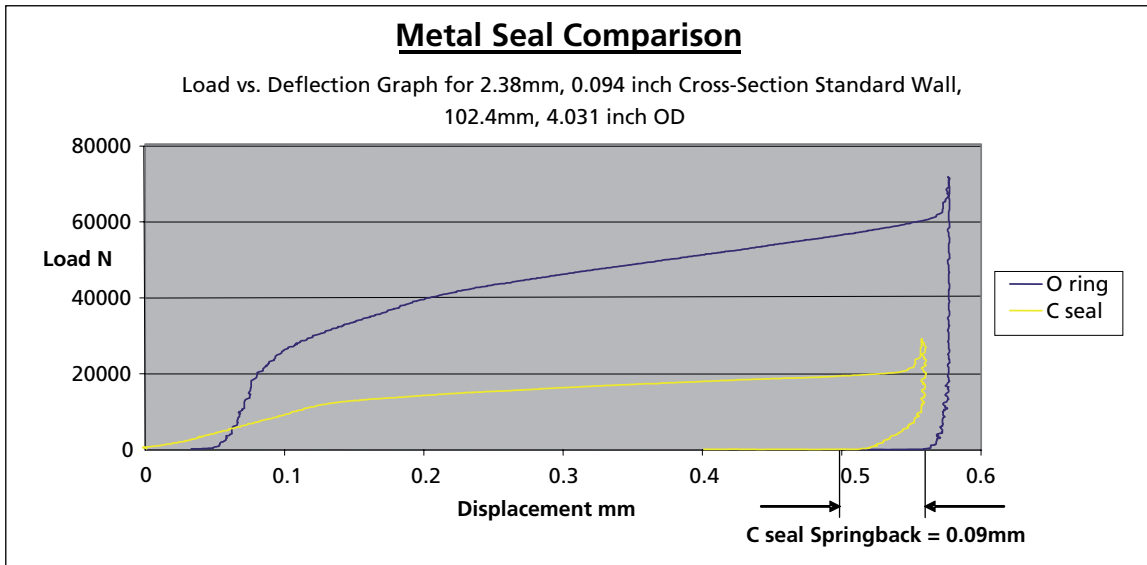

Figure 10 Graph detailing load vs. deflection comparison of two Wills Rings® types

**Note:**

It is not recommended to compress the seal less than the recommended amount in order to reduce the amount of load required to seat the seal. Using deeper grooves to reduce seating load could have an adverse effect on sealing efficiency. If lower seating loads are required, the correct seal type should be chosen with the correct coating.



## ■ Groove Designs

There are several types of groove which may be employed to house Wills Rings® depending upon the application and the system requirements, see Figure 12.

### 13.1 Closed groove

The seal is enclosed on its inside and outside diameters.

### 13.2 Open groove

The seal is enclosed by a groove wall opposing the pressure direction. For example, for internal pressure the groove wall is on the outside of the seal.

### 13.3 Retainer plate

If no groove can be constructed, then a plate of equal depth to the groove can be used to provide support to the seal.



Figure 11 Example of Wills Rings® with its groove

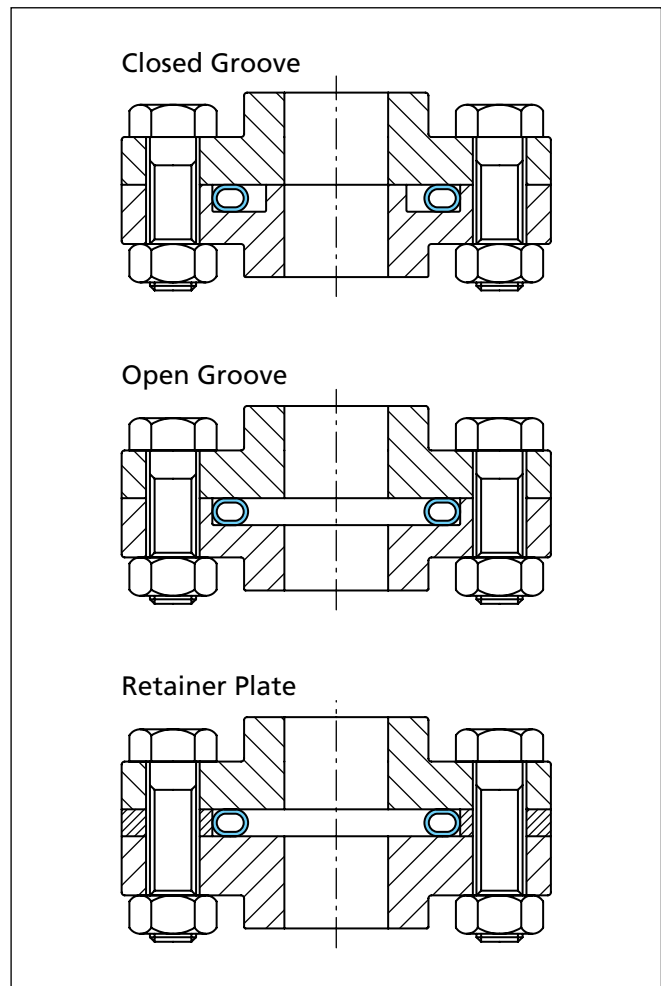

Figure 12 Common installation configurations for Wills Rings®

All installations above show Wills Rings® O installations.

The same housings can be used for Wills Rings® C installations.

See Figure 13 and comments for Wills Rings® O within automotive groove.



**Automotive Groove**

Another useful method of seal housing is using the automotive groove approach. This seal housing is commonly used for high-performance engines to seal the cylinder head to the engine block. Typically Wills Rings® O gas-filled seals are used here. Where cyclical engine pressures are found, this groove securely holds the Wills Rings® in place. Also the trapped volume of a closed groove is eliminated.

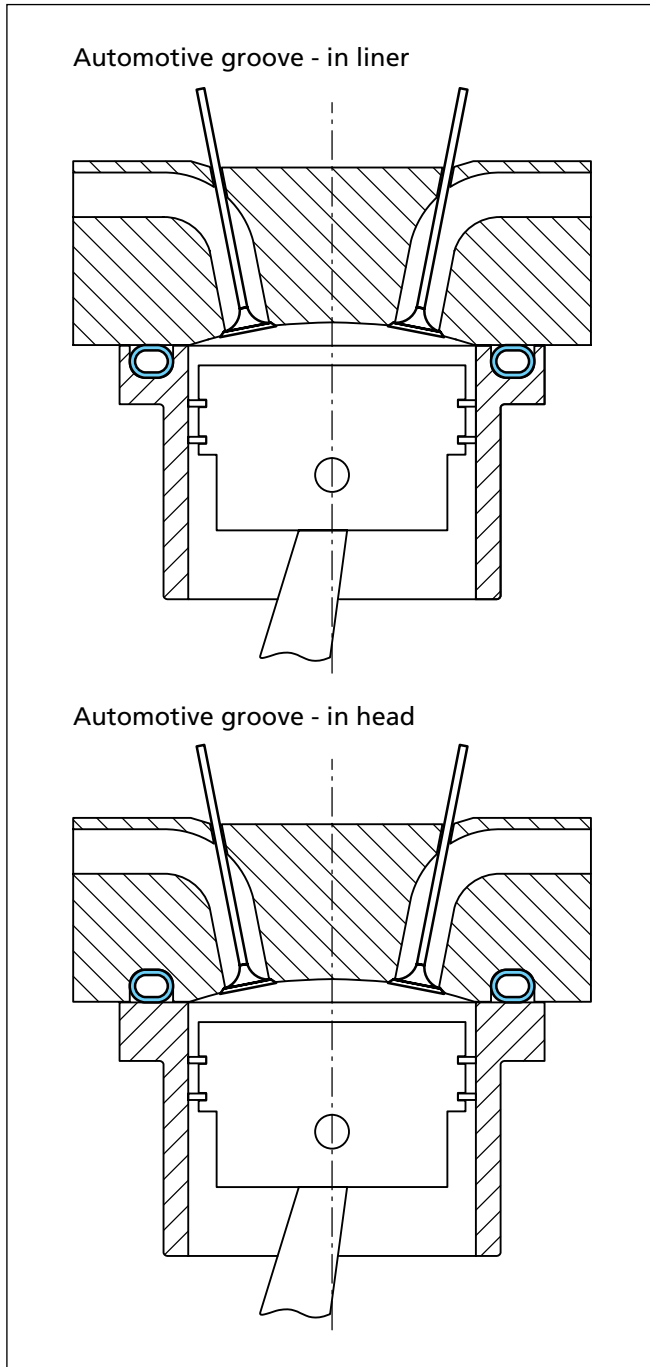

Figure 13 Common automotive installation configurations for Wills Rings® O

Figure 14 shows the preferred groove design for extreme cyclical pressures. The housing has a clearance from the seal inside and outside diameters, and the groove has a curved base. This design means the seal is held very securely and is protected from the media.

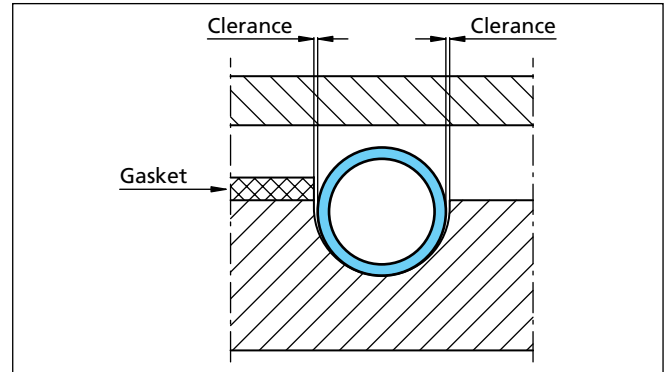

Figure 14 Detail of an automotive groove

The groove depth given for each free height  $d_2$  is the total compressed depth of Wills Rings® when installed. If an additional form of sealing is to be used, for example a gasket, then the machined depth of the housing groove must be less.

$$h = M_d + G_d$$

Where  $h$  = Groove depth (overall)  
 $M_d$  = Machined depth  
 $G_d$  = Crushed gasket depth

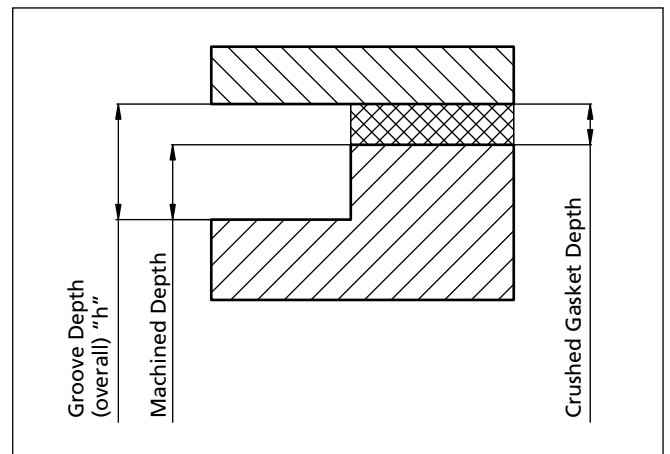

Figure 15 Wills Rings® groove depth with a gasket

For dimensions for automotive grooves please contact your local Trelleborg Sealing Solutions Marketing Company.



■ Part Numbers and Ordering Instructions in Metric

Installation Recommendations for Internal Pressure Sealing

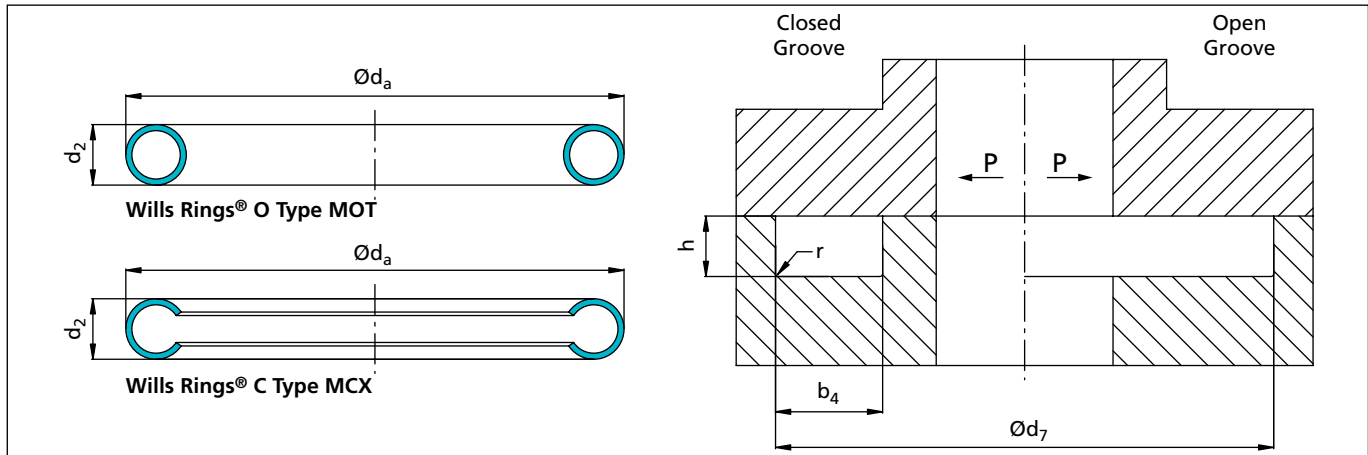

Figure 16 Installation drawing for internal pressure

Table 11 Installation Dimensions for Internal Pressure

Free Height d2 mm	Wills Rings® O		Type C		Groove Depth		Groove Width <sup>1)</sup> b4 min.	Wills Rings® O <sup>2)</sup> Øda	Groove Diameter d7, unplated only <sup>3)</sup> = da + clearance + tolerance		Radius r <sub>max</sub> mm	Wills Rings® Springback	
	Free Height Mat. Codes	Stand.	Thin	Free Height Mat. Codes	Stand.	Thin			h	O only		C only	
0.89			J	-	0.58	+0.08 -0	1.25	8-50	da +0.10	+0.05	0.25	0.01	-
1.59	A		A			1.32	+0.08 -0	2.25	da +0.10	+0.05	0.40	0.02	0.06
		K	K			0.03	0.07						
2.38	B		B			1.83	+0.08 -0	25-500 50-500	da +0.18	+0.12	0.50	0.04	0.09
		L	L			0.06	0.11						
3.18	C		C			2.54	+0.13 -0	60-1,000	da +0.18	+0.12	0.75	0.05	0.12
		M	M			0.11	0.14						
3.97	D		D			3.05	+0.13 -0	100-1,250	da +0.18	+0.12	1.25	0.06	0.11
		N	N			0.13	0.16						
4.76	E		E			3.68	+0.13 -0	115-1,500 150-1,500	da +0.25	+0.12	1.50	0.08	0.12
		O	O			0.17	0.23						
6.35	F		-			5.08	+0.13 -0	125-2,000	da +0.25	+0.12	1.50	0.10	0.27
		P	P			0.14	-						
7.94	G		-			6.35	+0.13 -0	500-2,500	da +0.38	+0.12	1.50	0.08	-
9.53	H		-			7.92	+0.13 -0	750-3,000	da +0.38	+0.12	1.50	0.08	-
		R	-			0.09	-						

- Notes: 1) Minimum value. Recommended groove width 1.5 x d2.  
 2) For Wills Rings® C diameter size ranges see page 24 (Table 18).  
 3) Calculate exact groove/seal Ø by the expression:  
 $d7 = da + (2 \times \text{maximum coating thickness}) + \text{clearance} (+ \text{tol.})$   
 $= da + \text{CTCV page 25 (Table 19), for clearance tolerance correction value}$

Example: 3.18 mm Wills Rings® C with three layers of plating  
 $d7 = da + (2 \times 3 \text{ layer coating} = 2 \times 0.085 \text{ mm} = 0.170 \text{ mm}) + \text{clearance} (+ \text{tol.})$   
 $= da + 0.170 + \text{clearance} (+ \text{tol.})$   
 $= da + 0.170 + 0.18 (+0.12)$



## Wills Rings® O for Internal Pressure

These are typical of seal part numbers which can be ordered using the groove diameter. Other sizes, materials or finishes may be ordered by referring to the ordering example on page 26 and the seal data. See also page 6 and page 7, Tables 2 to 4.

**Table 12 Preferred Sizes Wills Rings® O, Metric**

Seal Diameter	Seal Non-plated	Groove Ød7 H9	Seal 1 Layer	Groove Ød7 H9	Minimum Groove Width b4	Groove Depth h
10	MOT J R0100-1_	10.15	MOT J R0100-1_R	10.22	1.25	0.58/0.66
12	MOT J R0120-1_	12.15	MOT J R0120-1_R	12.22	1.25	0.58/0.66
15	MOT A R0150-1_	15.15	MOT A R0150-1_R	15.22	2.25	1.32/1.40
20	MOT A R0200-1_	20.15	MOT A R0200-1_R	20.22	2.25	1.32/1.40
25	MOT A R0250-1_	25.15	MOT A G0250-1_R	25.22	2.25	1.32/1.40
30	MOT B R0300-1_	30.30	MOT B R0300-1_R	30.37	3.00	1.83/1.91
35	MOT B R0350-1_	35.30	MOT B R0350-1_R	35.37	3.00	1.83/1.91
40	MOT B R0400-1_	40.30	MOT B R0400-1_R	40.37	3.00	1.83/1.91
45	MOT B R0450-1_	45.30	MOT B R0450-1_R	45.37	3.00	1.83/1.91
50	MOT B R0500-1_	50.30	MOT B R0500-1_R	50.37	3.00	1.83/1.91
55	MOT B R0550-1_	55.30	MOT B R0550-1_R	55.37	3.00	1.83/1.91
60	MOT B R0600-1_	60.30	MOT B R0600-1_R	60.37	3.00	1.83/1.91
65	MOT C R0650-1_	65.30	MOT C R0650-1_R	65.37	4.00	2.54/2.67
70	MOT C R0700-1_	70.30	MOT C R0700-1_R	70.37	4.00	2.54/2.67
75	MOT C R0750-1_	75.30	MOT C R0750-1_R	75.37	4.00	2.54/2.67
80	MOT C R0800-1_	80.30	MOT C R0800-1_R	80.37	4.00	2.54/2.67
85	MOT C R0850-1_	85.30	MOT C R0850-1_R	85.37	4.00	2.54/2.67
90	MOT C R0900-1_	90.30	MOT C R0900-1_R	90.37	4.00	2.54/2.67
95	MOT C R0950-1_	95.30	MOT C R0950-1_R	95.37	4.00	2.54/2.67
100	MOT C R1000-1_	100.30	MOT C R1000-1_R	100.37	4.00	2.54/2.67
110	MOT D R1100-1_	110.30	MOT D R1100-1_R	110.37	5.00	3.05/3.18
120	MOT D R1200-1_	120.30	MOT D R1200-1_R	120.37	5.00	3.05/3.18
130	MOT D R1300-1_	130.30	MOT D R1300-1_R	130.37	5.00	3.05/3.18
140	MOT D R1400-1_	140.30	MOT D R1400-1_R	140.37	5.00	3.05/3.18
150	MOT D R1500-1_	150.30	MOT D R1500-1_R	150.37	5.00	3.05/3.18
160	MOT D R1600-1_	160.30	MOT D R1600-1_R	160.37	5.00	3.05/3.18
170	MOT E R1700-1_	170.37	MOT E R1700-1_R	170.44	6.00	3.68/3.81
180	MOT E R1800-1_	180.37	MOT E R1800-1_R	180.44	6.00	3.68/3.81
190	MOT E R1900-1_	190.37	MOT E R1900-1_R	190.44	6.00	3.68/3.81
200	MOT E R2000-1_	200.37	MOT E R2000-1_R	200.44	6.00	3.68/3.81
250	MOT E R2500-1_	250.37	MOT E R2500-1_R	250.44	6.00	3.68/3.81

### Use this selection when designing a new housing/sealing system

Also applies to Wills Rings® O for Type MOV, MOS & MOU

#### Note:

These seal part numbers use ring sizing (indicated by "R" in the ø code). The seal ø has a clearance fit depending upon the plating used. See the Clearance - Tolerance Correction Value, see Table 19 on page 25.



## Wills Rings® C for Internal Pressure

These are typical of seal part numbers which can be ordered using the groove diameter. Other sizes, materials or finishes may be ordered by referring to the order C example on page 27 and the seal data. See also page 6 and page 7, Tables 2 to 4.

**Table 13 Preferred Sizes Wills Rings® C, Metric**

Seal Diameter	Seal Non-plated	Groove Ød7 H9	Seal 1 Layer	Groove Ød7 H9	Minimum Groove Width b4	Groove Depth h
20	MCX A R0200-1_2	20.15	MCX A R0200-1_R2	20.22	2.25	1.32/1.40
25	MCX A R0250-1_2	25.15	MCX A R0250-1_R2	25.22	2.25	1.32/1.40
30	MCX A R0300-1_2	30.15	MCX A R0300-1_R2	30.22	2.25	1.32/1.40
35	MCX A R0350-1_2	35.15	MCX A R0350-1_R2	35.22	2.25	1.32/1.40
40	MCX A R0400-1_2	40.15	MCX A R0400-1_R2	40.22	2.25	1.32/1.40
50	MCX A R0500-1_2	50.15	MCX A R0500-1_R2	50.22	2.25	1.32/1.40
30	MCX B R0300-1_2	30.30	MCX B R0300-1_R2	30.37	3.00	1.83/1.91
40	MCX B R0400-1_2	40.30	MCX B R0400-1_R2	40.37	3.00	1.83/1.91
50	MCX B R0500-1_2	50.30	MCX B R0500-1_R2	50.37	3.00	1.83/1.91
60	MCX B R0600-1_2	60.30	MCX B R0600-1_R2	60.37	3.00	1.83/1.91
70	MCX B R0700-1_2	70.30	MCX B R0700-1_R2	70.37	3.00	1.83/1.91
80	MCX B R0800-1_2	80.30	MCX B R0800-1_R2	80.37	3.00	1.83/1.91
90	MCX B R0900-1_2	90.30	MCX B R0900-1_R2	90.37	3.00	1.83/1.91
70	MCX C R0700-1_2	70.30	MCX C R0700-1_R2	70.37	4.00	2.54/2.67
80	MCX C R0800-1_2	80.30	MCX C R0800-1_R2	80.37	4.00	2.54/2.67
90	MCX C R0900-1_2	90.30	MCX C R0900-1_R2	90.37	4.00	2.54/2.67
100	MCX C R1000-1_2	100.30	MCX C R1000-1_R2	100.37	4.00	2.54/2.67
110	MCX C R1100-1_2	110.30	MCX C R1100-1_R2	110.37	4.00	2.54/2.67
150	MCX C R1500-1_2	150.30	MCX C R1500-1_R2	150.37	4.00	2.54/2.67
110	MCX D R1100-1_2	110.30	MCX D R1100-1_R2	110.37	5.00	3.05/3.18
120	MCX D R1200-1_2	120.30	MCX D R1200-1_R2	120.37	5.00	3.05/3.18
130	MCX D R1300-1_2	130.30	MCX D R1300-1_R2	130.37	5.00	3.05/3.18
140	MCX D R1400-1_2	140.30	MCX D R1400-1_R2	140.37	5.00	3.05/3.18
150	MCX D R1500-1_2	150.30	MCX D R1500-1_R2	150.37	5.00	3.05/3.18
160	MCX D R1600-1_2	160.30	MCX D R1600-1_R2	160.37	5.00	3.05/3.18
160	MCX E R1600-1_2	160.37	MCX E R1600-1_R2	160.44	6.00	3.68/3.81
170	MCX E R1700-1_2	170.37	MCX E R1700-1_R2	170.44	6.00	3.68/3.81
180	MCX E R1800-1_2	180.37	MCX E R1800-1_R2	180.44	6.00	3.68/3.81
190	MCX E R1900-1_2	190.37	MCX E R1900-1_R2	190.44	6.00	3.68/3.81
200	MCX E R2000-1_2	200.37	MCX E R2000-1_R2	200.44	6.00	3.68/3.81
160	MCX P R1600-1_2	160.37	MCX P R1600-1_R2	160.44	8.00	5.08/5.21
170	MCX P R1700-1_2	170.37	MCX P R1700-1_R2	170.44	8.00	5.08/5.21
180	MCX P R1800-1_2	180.37	MCX P R1800-1_R2	180.44	8.00	5.08/5.21
190	MCX P R1900-1_2	190.37	MCX P R1900-1_R2	190.44	8.00	5.08/5.21
200	MCX P R2000-1_2	200.37	MCX P R2000-1_R2	200.44	8.00	5.08/5.21

**Use this selection when designing a new housing/sealing system.**

**Note:**

These seal part numbers use ring sizing (indicated by "R" in the ø code). The seal ø has a clearance fit depending upon the plating used. See the Clearance - Tolerance Correction Value, see Table 19 on page 25.



**Installation Recommendations for External Pressure Sealing**

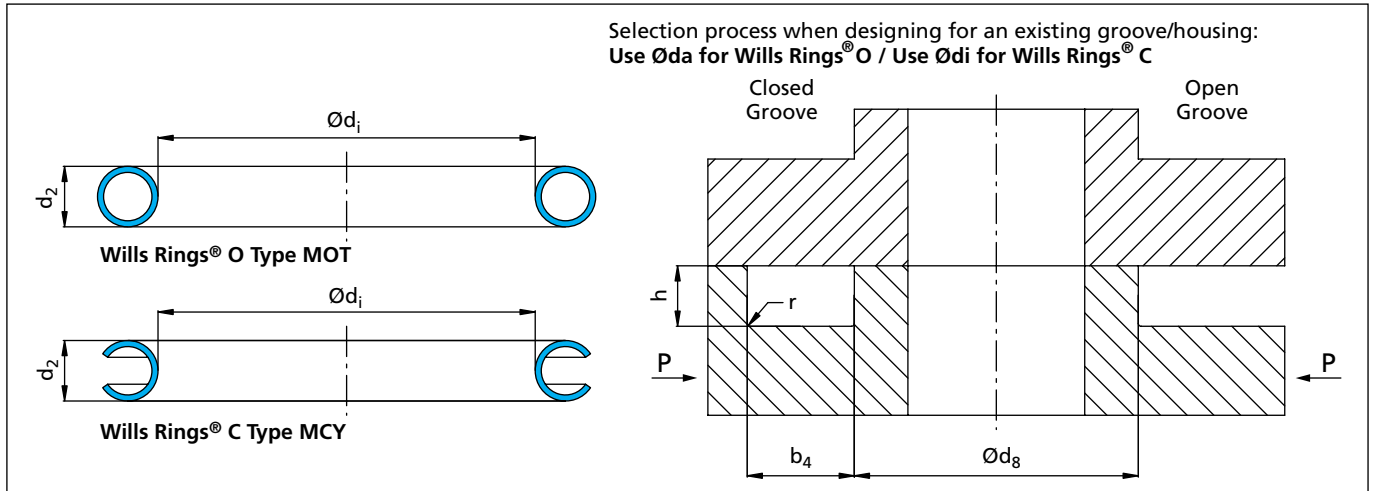

Figure 17 Installation drawing for external pressure

**Table 14 Installation Dimensions for External Pressure**

Free Height <b>d2 mm</b>	Wills Rings® <b>O</b>		Wills Rings® <b>C</b>		Groove Depth		Groove Width <sup>1)</sup> <b>b4 min.</b>	Wills Rings® <b>O</b> <sup>2)</sup> <b>Øda</b>	Groove Diameter d8, unplated only <sup>3)</sup> <b>= di - clearance + tolerance</b>		Radius <b>r<sub>max</sub></b> mm	Wills Rings® <b>Springback</b>	
	Free Height Mat. Codes	Stand.	Thin	Free Height Mat. Codes	Stand.	Thin			h	O only		C only	
0.89			J	-	0.58	+0.08 -0	1.25	8-50	di -0.10	-0.05	0.25	0.01	-
1.59	A			K	1.32	+0.08 -0	2.25	12-150	di -0.10	-0.05	0.40	0.02 0.03	0.06 0.07
2.38	B			L	1.83	+0.08 -0	3.00	25-500 50-500	di -0.18	-0.12	0.50	0.04 0.06	0.09 0.11
3.18	C			M	2.54	+0.13 -0	4.00	60-1000	di -0.18	-0.12	0.75	0.05 0.11	0.12 0.14
3.97	D			N	3.05	+0.13 -0	5.00	100-1250	di -0.18	-0.12	1.25	0.06 0.13	0.11 0.16
4.76	E			O	3.68	+0.13 -0	6.00	115-1500 150-1500	di -0.25	-0.12	1.50	0.08 0.17	0.12 0.23
6.35	F			P	5.08	+0.13 -0	8.00	125-2000	di -0.25	-0.12	1.50	0.10 0.14	0.27
7.94	G			-	6.35	+0.13 -0	10.00	500-2500	di -0.38	-0.12	1.50	0.08	-
9.53	H			R	7.92	+0.13 -0	12.00	750-3000	di -0.38	-0.12	1.50	0.08 0.09	-

- Notes: 1) Minimum value. Recommended is groove width 1.5 x d2.  
 2) For Wills Rings® C diameter size ranges see page 24 (Table 18).  
 3) Calculate exact groove/seal Ø by the expression:  
 $d8 = di - (2 \times \text{maximum coating thickness}) - \text{clearance} (- \text{tol.})$   
 $= di - \text{CTCV page 25 (Table 19), for clearance tolerance correction value}$

Example: 2.38 mm Wills Rings® O with 1 layers of plating  
 $d8 = di - (2 \times 1 \text{ layer coating} = 2 \times 0.035 \text{ mm} = 0.070 \text{ mm}) - \text{clearance} (- \text{tol.})$   
 $= di - 0.070 - \text{clearance} (- \text{tol.})$   
 $= di - 0.070 - 0.18 (-0.12)$   
 $= di - 0.37 \text{ mm}$



## Wills Rings® O for External Pressure

These are typical of seal part numbers which can be ordered using the groove diameter. Other sizes, materials or finishes may be ordered by referring to the ordering example on page 26 and the seal data. See also page 6 and page 7, Tables 2 to 4.

**Table 15 Preferred Sizes Wills Rings® O, Metric**

Seal Diameter	Seal Non-plated	Groove ID	Seal 1 Layer	Groove ID	Minimum Groove Width	Groove Depth
		Ød8 h9		Ød8 h9		
10	MOT J R0100-1_	8.07	MOT J R0100-1_R	8.00	1.25	0.58/0.66
12	MOT J R0120-1_	10.07	MOT J R0120-1_R	10.00	1.25	0.58/0.66
15	MOT A R0150-1_	11.67	MOT A R0150-1_R	11.60	2.25	1.32/1.40
20	MOT A R0200-1_	16.67	MOT A R0200-1_R	16.60	2.25	1.32/1.40
25	MOT A R0250-1_	21.67	MOT A G0250-1_R	21.60	2.25	1.32/1.40
30	MOT B R0300-1_	24.94	MOT B R0300-1_R	24.87	3.00	1.83/1.91
35	MOT B R0350-1_	29.94	MOT B R0350-1_R	29.87	3.00	1.83/1.91
40	MOT B R0400-1_	34.94	MOT B R0400-1_R	35.87	3.00	1.83/1.91
45	MOT B R0450-1_	39.94	MOT B R0450-1_R	39.87	3.00	1.83/1.91
50	MOT B R0500-1_	44.94	MOT B R0500-1_R	45.87	3.00	1.83/1.91
55	MOT B R0550-1_	49.94	MOT B R0550-1_R	49.87	3.00	1.83/1.91
60	MOT B R0600-1_	54.94	MOT B R0600-1_R	54.87	3.00	1.83/1.91
65	MOT C R0650-1_	58.34	MOT C R0650-1_R	58.27	4.00	2.54/2.67
70	MOT C R0700-1_	63.34	MOT C R0700-1_R	63.27	4.00	2.54/2.67
75	MOT C R0750-1_	68.34	MOT C R0750-1_R	68.27	4.00	2.54/2.67
80	MOT C R0800-1_	73.34	MOT C R0800-1_R	73.27	4.00	2.54/2.67
85	MOT C R0850-1_	78.34	MOT C R0850-1_R	78.27	4.00	2.54/2.67
90	MOT C R0900-1_	83.34	MOT C R0900-1_R	83.27	4.00	2.54/2.67
95	MOT C R0950-1_	88.34	MOT C R0950-1_R	88.27	4.00	2.54/2.67
100	MOT C R1000-1_	93.34	MOT C R1000-1_R	93.27	4.00	2.54/2.67
110	MOT D R1100-1_	101.76	MOT D R1100-1_R	101.69	5.00	3.05/3.18
120	MOT D R1200-1_	111.76	MOT D R1200-1_R	110.69	5.00	3.05/3.18
130	MOT D R1300-1_	121.76	MOT D R1300-1_R	120.69	5.00	3.05/3.18
140	MOT D R1400-1_	131.76	MOT D R1400-1_R	130.69	5.00	3.05/3.18
150	MOT D R1500-1_	141.76	MOT D R1500-1_R	140.69	5.00	3.05/3.18
160	MOT D R1600-1_	151.76	MOT D R1600-1_R	150.69	5.00	3.05/3.18
170	MOT E R1700-1_	160.11	MOT E R1700-1_R	160.04	6.00	3.68/3.81
180	MOT E R1800-1_	170.11	MOT E R1800-1_R	170.04	6.00	3.68/3.81
190	MOT E R1900-1_	180.11	MOT E R1900-1_R	180.04	6.00	3.68/3.81
200	MOT E R2000-1_	190.11	MOT E R2000-1_R	190.04	6.00	3.68/3.81
250	MOT E R2500-1_	240.11	MOT E R2500-1_R	240.04	6.00	3.68/3.81

**Use this selection when designing a new housing/sealing system.**

Also applies to Wills Rings® O for Type MOW, MOS & MOU.

**Note:**

These seal part numbers use ring sizing (indicated by "R" in the ø code) and the groove ød8. The seal ø has a clearance fit depending upon the plating used. See the Clearance - Tolerance Correction Value, see table 19 on page 25.





**Wills Rings® C for External Pressure**

These are typical of seal part numbers which can be ordered using the groove diameter. Other sizes, materials or finishes may be ordered by referring to the order example on page 27 and the seal data. See also page 6 and page 7, Tables 2 to 4.

**Table 16 Preferred Sizes Wills Rings® C, Metric**

Seal Diameter	Seal Non-plated	Groove ID Ød8 h9	Seal 1 Layer	Groove ID Ød8 h9	Minimum Groove Width b4	Groove Depth h
20	MCY A R0200-1_2	19.85	MCY A R0200-1_R2	19.78	2.25	1.32/1.40
25	MCY A R0250-1_2	24.85	MCY A R0250-1_R2	24.78	2.25	1.32/1.40
30	MCY A R0300-1_2	29.85	MCY A R0300-1_R2	29.78	2.25	1.32/1.40
35	MCY A R0350-1_2	34.85	MCY A R0350-1_R2	34.78	2.25	1.32/1.40
40	MCY A R0400-1_2	39.85	MCY A R0400-1_R2	39.78	2.25	1.32/1.40
50	MCY A R0500-1_2	49.85	MCY A R0500-1_R2	49.78	2.25	1.32/1.40
30	MCY B R0300-1_2	29.70	MCY B R0300-1_R2	29.63	3.00	1.83/1.91
40	MCY B R0400-1_2	39.70	MCY B R0400-1_R2	39.63	3.00	1.83/1.91
50	MCY B R0500-1_2	49.70	MCY B R0500-1_R2	49.63	3.00	1.83/1.91
60	MCY B R0600-1_2	59.70	MCY B R0600-1_R2	59.63	3.00	1.83/1.91
70	MCY B R0700-1_2	69.70	MCY B R0700-1_R2	69.63	3.00	1.83/1.91
80	MCY B R0800-1_2	79.70	MCY B R0800-1_R2	79.63	3.00	1.83/1.91
90	MCY B R0900-1_2	89.70	MCY B R0900-1_R2	89.63	3.00	1.83/1.91
70	MCY C R0700-1_2	69.70	MCY C R0700-1_R2	69.63	4.00	2.54/2.67
80	MCY C R0800-1_2	79.70	MCY C R0800-1_R2	79.63	4.00	2.54/2.67
90	MCY C R0900-1_2	89.70	MCY C R0900-1_R2	89.63	4.00	2.54/2.67
100	MCY C R1000-1_2	99.70	MCY C R1000-1_R2	99.63	4.00	2.54/2.67
110	MCY C R1100-1_2	109.70	MCY C R1100-1_R2	109.63	4.00	2.54/2.67
150	MCY C R1500-1_2	149.70	MCY C R1500-1_R2	149.63	4.00	2.54/2.67
110	MCY D R1100-1_2	109.70	MCY D R1100-1_R2	109.63	5.00	3.05/3.18
120	MCY D R1200-1_2	119.70	MCY D R1200-1_R2	119.63	5.00	3.05/3.18
130	MCY D R1300-1_2	129.70	MCY D R1300-1_R2	129.63	5.00	3.05/3.18
140	MCY D R1400-1_2	139.70	MCY D R1400-1_R2	139.63	5.00	3.05/3.18
150	MCY D R1500-1_2	149.70	MCY D R1500-1_R2	149.63	5.00	3.05/3.18
160	MCY D R1600-1_2	159.70	MCY D R1600-1_R2	159.63	5.00	3.05/3.18
160	MCY E R1600-1_2	159.63	MCY E R1600-1_R2	159.56	6.00	3.68/3.81
170	MCY E R1700-1_2	169.63	MCY E R1700-1_R2	169.56	6.00	3.68/3.81
180	MCY E R1800-1_2	179.63	MCY E R1800-1_R2	179.56	6.00	3.68/3.81
190	MCY E R1900-1_2	189.63	MCY E R1900-1_R2	189.56	6.00	3.68/3.81
200	MCY E R2000-1_2	199.63	MCY E R2000-1_R2	199.56	6.00	3.68/3.81
160	MCY P R1600-1_2	159.63	MCY P R1600-1_R2	159.56	8.00	5.08/5.21
170	MCY P R1700-1_2	169.63	MCY P R1700-1_R2	169.56	8.00	5.08/5.21
180	MCY P R1800-1_2	179.63	MCY P R1800-1_R2	179.56	8.00	5.08/5.21
190	MCY P R1900-1_2	189.63	MCY P R1900-1_R2	189.56	8.00	5.08/5.21
200	MCY P R2000-1_2	199.63	MCY P R2000-1_R2	199.56	8.00	5.08/5.21

**Use this selection when designing a new housing/sealing system.**

**Note:**

These seal part numbers use ring sizing (indicated by "R" in the ø code) and the groove ød8. The seal ø has a clearance fit depending upon the plating used. See the Clearance - Tolerance Correction Value, see table 19 on page 25.



## ■ Metric Part Numbers and Ordering Instructions

### Metric Size Ranges and Free Heights

Wills Rings® are available in a comprehensive range of sizes. Free height ranges – from 0.89 mm to 9.53 mm and for each size there is a range of seal diameters which can be produced. Free height sizes are to industry standards and have evolved from inch sizes. See Table 17 and 18.

**Table 17 Diameter Size Range for Wills Rings® O**

Free Height	Wall Code	Wall Thickness	Seal	Total Groove Depth <sup>1)</sup>	Groove Width <sup>2)</sup>
d2 mm		mm	Ø da mm	h mm	b4 min. mm
0.89	J	0.15	8-50	0.58 +0.08 -0	1.25
1.59	A	0.36	12-150	1.32 +0.08 -0	2.25
	K	0.25			
2.38	B	0.46	25-500	1.83 +0.08 -0	3.00
	L	0.25	50-500		
3.18	C	0.51	60-1000	2.54 +0.13 -0	4.00
	M	0.25			
3.97	D	0.64	100-1250	3.05 +0.13 -0	5.00
	N	0.25			
4.76	E	0.81	115-1500	3.68 +0.13 -0	6.00
	O	0.25	150-1500		
6.35	F	1.02	125-2000	5.08 +0.13 -0	8.00
	P	0.51			
7.94	G	1.27	500-2500	6.35 +0.13 -0	10.00
	-	-			
9.53	H	1.52	750-3000	7.92 +0.13 -0	12.00
	R	0.51			

**Table 18 Diameter Size Range for Wills Rings® C**

Free Height	Wall Code	Wall Thickness	Seal	Total Groove Depth <sup>1)</sup>	Groove Width <sup>2)</sup>
d2 mm		mm	Ø da mm	h mm	b4 min. mm
-	-	-	-	-	-
1.59	A	0.25	20-150	1.32 +0.08 -0	2.25
	K	0.15			
2.38	B	0.38	25-300	1.83 +0.08 -0	3.00
	L	0.25			
3.18	C	0.51	50-400	2.54 +0.13 -0	4.00
	M	0.38			
3.97	D	0.61	60-500	3.05 +0.13 -0	5.00
	N	0.41			
4.76	E	0.76	95-500	3.68 +0.13 -0	6.00
	O	0.51			
6.35	-	-	115-500	5.08 +0.13 -0	8.00
	P	0.64			

**Note:**

1) When using a gasket in conjunction with Wills Rings® the groove depth must be modified. Please refer to the section on groove design, and in particular on automotive groove design, on page 17, Figure 13, 14 and 15.

2) Groove width given in Table 17 and Table 18 is the minimum. Ideally the groove width b4 = 1.5 x d2.

See page 28 for Size Ranges and Free Heights in Inches.



## Metric Groove Clearance and Plating Allowances

The table below gives guidance on how to size a seal for a given groove diameter. This will enable sizing of seals correctly for a given groove diameter, or vice versa.

**Table 19 Clearance - Tolerance Correction Value in mm**

			No Plating		One Layer		Two Layers		Three Layers	
Maximum Plating			0.00		+ 0.035		+ 0.060		+ 0.085	
2 x maximum Plating			0.00		+ 0.070		+ 0.120		+ 0.170	
Free Height										
mm	code		Total		Total		Total		Total	
0.89	-	J	0.10+0.05	<b>0.15</b>	0.17+0.05	<b>0.22</b>	0.22+0.05	<b>0.27</b>	0.27+0.05	<b>0.32</b>
1.59	A	K	0.10+0.05		0.17+0.05		0.22+0.05		0.27+0.05	
2.38	B	L	0.18+0.12	<b>0.30</b>	0.25+0.12	<b>0.37</b>	0.30+0.12	<b>0.42</b>	0.35+0.12	<b>0.47</b>
3.18	C	M	0.18+0.12		0.25+0.12		0.30+0.12		0.35+0.12	
3.97	D	N	0.18+0.12		0.25+0.12		0.30+0.12		0.35+0.12	
4.76	E	O	0.25+0.12	<b>0.37</b>	0.32+0.12	<b>0.44</b>	0.37+0.12	<b>0.49</b>	0.42+0.12	<b>0.54</b>
6.35	F	P	0.25+0.12		0.32+0.12		0.37+0.12		0.42+0.12	
7.94	G	-	0.38+0.12	<b>0.50</b>	0.45+0.12	<b>0.57</b>	0.50+0.12	<b>0.62</b>	0.55+0.12	<b>0.67</b>
9.53	H	R	0.38+0.12		0.45+0.12		0.50+0.12		0.55+0.12	

Wills Rings® clearance and tolerance correction values (CTCV) for different plating levels for each free height size.

See page 29 for Clearance Tolerance Correction Values in Inches.

Internal pressure  $\varnothing d7 = \varnothing da + \text{CTCV}$

External pressure  $\varnothing d8 = \varnothing di - \text{CTCV}$

**Note:**

Use  $\varnothing da$  for Wills Rings® O for external pressure

Use  $\varnothing di$  for Wills Rings® C for external pressure

For example

MOTOG1500K1HS

This is a 4.76 mm gas-filled Wills Rings® O thin wall seal for a 150.0 mm groove diameter d7. It has silver plate at 3 layers, 0.075/0.085 mm thickness.

The seal diameter is found from  $\varnothing d7 = \varnothing da + \text{CTCV}$

$$\begin{aligned} \text{Hence } \varnothing da &= \varnothing d7 - \text{CTCV} \\ &= 150.0 - 0.54 \\ \varnothing da &= 149.46 \text{ mm} \end{aligned}$$



Metric Part Number Systems for Wills Rings®

Table 20 Metric Part Number System for Wills Rings® O in Metric

Seal Type	Series	Free Height/ Wall Size mm	Seal Diameter	Quality Characteristic Code	Characteristic Number	Seal Material	Coating Material	Treat- ment
M O M Metal O O-Ring profile	S Solid T Gas-filled U Non- Pressurized V Pressure vented ID W Pressure vented OD	Standard wall	Diameter x 10 (up to) 999.9)  G - - - - this is the groove outside diameter Ød7 x 10  Use the groove method only for internal pressure/ external sealing  R - - - - this is the ring outside dia. Øda x 10	"- " Standard Quality  "K" X-Ray required  "A" Aerospace use	1 = Standard	B Mild steel	Q Nickel	5 = Heat treatment to NACE MR0175 (Inconel® 718 only)
		A 1.59 0.36				H Stainless Steel AISI 316L (1.4435)	O Copper	
		B 2.38 0.46				E Stainless Steel AISI 321 (1.4541)	I Gold	
		C 3.18 0.51				M Inconel® 600	N Indium	
		D 3.97 0.64				L Inconel® 718	R Silver One layer	
		E 4.76 0.81				O Copper	U Silver Two layers	
		F 6.35 1.02					S Silver Three layers	
		G 7.94 1.27						
		H 9.53 1.52						
		J 0.89 0.15						
		K 1.59 0.25						
		L 2.38 0.25						
		M 3.18 0.25						
		N 3.97 0.25						
		O 4.76 0.25						
P 6.35 0.51								
R 9.53 0.51								

Notes:

MOV/MOW (pressure vented type) seal not available in 0.89 mm free height. Use MOT type or increase to a 1.59 mm size instead. Other non-standard plating/coating options are available. Ask your local Trelleborg Marketing Company for further details. Select Quality Characteristic Code K for Thin wall rings.

Example 1

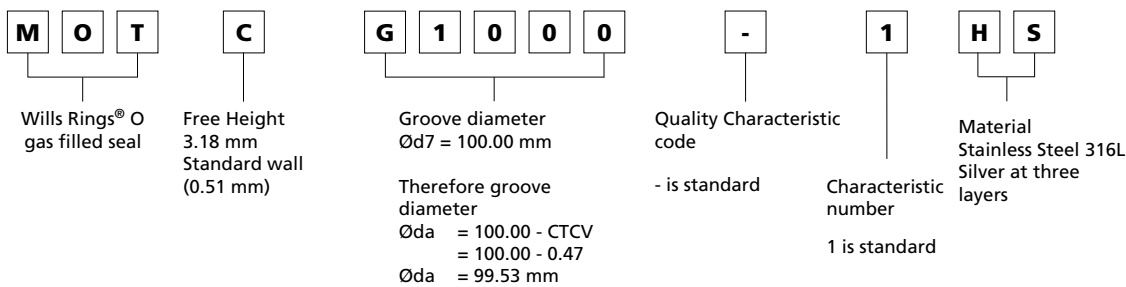

Example 2

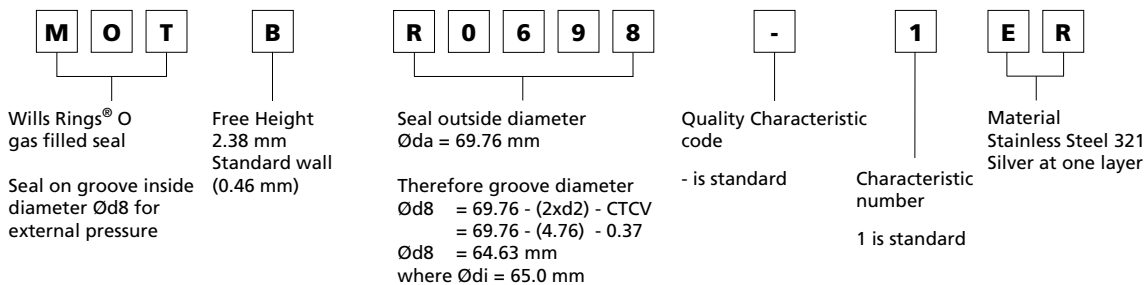

See page 30 for part number system in Inches.



**Table 21 Metric Part Number System for Wills Rings® C**

Seal Type	Series	Free Height/ Wall Size mm	Seal Diameter	Quality Characteristic Code	Characteristic Number	Seal Material	Coating Material	Treatment	
M C M Metal C C-Ring profile	X Internal pressure	Standard wall	(up to) 999.9	"- Standard Quality	1 = Standard	L Inconel® 718	O Copper	1 = Work hardened	
		A 1.59 0.25	G - - - - this is the groove diameter (Ød7 or ød8) x10						
		B 2.38 0.38							
		C 3.18 0.51							
		D 3.97 0.61							
		E 4.76 0.76							
	Y External pressure	Thin wall	R - - - - this is the seal diameter (Øda or Ødi) x 10	"A" Aerospace use		L Inconel® 718	N Inconel® X750	R Silver One layer	3 = Age hardened (long cycle)
		K 1.59 0.15							
		L 2.38 0.25							
		M 3.18 0.38	Use outside diameter for internal pressure/ outside sealing						
		N 3.97 0.41							
		O 4.76 0.51							
		P 6.35 0.64							
			Use inside diameter for external pressure/inside sealing						

**Notes:**

Other non-standard plating/coating options are available.

Treatment code 5 for seal material Inconel® 718 only.

**Example 1**

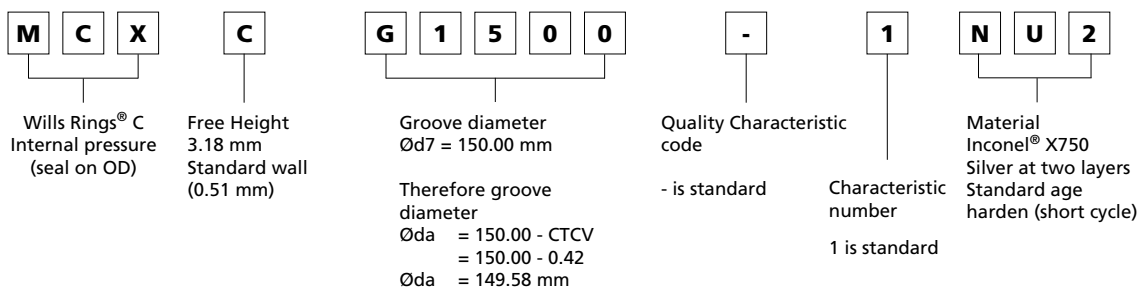

**Example 2**

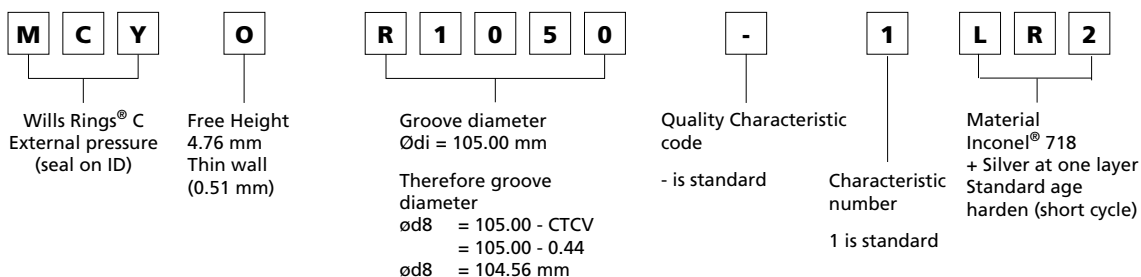

See page 31 for part number system in Inches.



## ■ Inch Part Numbers and Ordering Instructions

### Inch Size Ranges and Free Heights

**Table 22 Diameter Size Range in Inches for Wills Rings® O**

Free Height d2 inch	Wall Code	Wall inch	Seal Ø da inch	Total Groove Depth <sup>1)</sup> h inch	Groove Width <sup>2)</sup> b4 min. inch
0.035	J	0.006	0.313-2	0.023 +0.003 -0	0.050
0.063	A	0.014	0.5-6	0.052 +0.003	0.089
	K	0.010		-0	
0.094	B	0.018	1-20	0.072 +0.003	0.118
	L	0.010	2-20	-0	
0.125	C	0.020	2.5-40	0.100 +0.005	0.157
	M	0.010		-0	
0.156	D	0.025	4-60	0.120 +0.005	0.197
	N	0.010		-0	
0.187	E	0.032	4.5-60	0.145 +0.005	0.236
	O	0.010	6-60	-0	
0.250	F	0.040	5-80	0.200 +0.005	0.315
	P	0.020		-0	
0.313	G	0.050	20-100	0.250 +0.005	0.394
	-	-		-0	
0.375	H	0.060	30-120	0.312 +0.005	0.472
	R	0.020		-0	

Wills Rings® are available in a comprehensive range of sizes. Free height ranges from 0.035 inch to 0.375 inch and for each size there is a range of seal diameters which can be produced. Free height sizes are industry standard and have evolved from inch sizes. See Table 22 and Table 23.

**Table 23 Diameter Size Range in Inches for Wills Rings® C**

Free Height d2 inch	Wall Code	Wall inch	Seal Ø da inch	Total Groove Depth <sup>1)</sup> h inch	Groove Width <sup>2)</sup> b4 min. inch
-	-	-	-	-	-
0.063	A	0.010	0.8-6	0.052 +0.003	0.089
	K	0.006		-0	
0.094	B	0.015	1-12	0.072 +0.003	0.118
	L	0.010		-0	
0.125	C	0.020	2-16	0.100 +0.005	0.157
	M	0.015		-0	
0.156	D	0.024	2.4-20	0.120 +0.005	0.197
	N	0.016		-0	
0.187	E	0.030	3.75-20	0.145 +0.005	0.236
	O	0.020		-0	
0.250	-	-	4.5-20	0.200 +0.005	0.315
	P	0.025		-0	

See page 24 for Size Ranges and Free Heights in Metric.

**Note:**

- 1) When using a gasket in conjunction with Wills Rings® the groove depth must be modified. Please refer to the section on groove design, and in particular on automotive groove design on page 17, Figure 13, 14 and 15.
- 2) Groove width given in Table 22 and Table 23 is the minimum. Ideally the groove width  $b_4 = 1.5 \times d_2$ .



## Inch Groove Clearance and Plating Allowances

The table below gives guidance on how to size a seal for a given groove diameter. This will enable sizing of seals correctly for a given groove diameter, or vice versa.

**Table 24 Inch Clearance - Tolerance Correction Value**

		No Plating		One Layer		Two Layers		Three Layers		
Maximum Plating		0.00		+ 0.0015		+ 0.0025		+ 0.0035		
2 x maximum Plating		0.00		+ 0.003		+ 0.005		+ 0.007		
Free Height										
inch	code		Total		Total		Total		Total	
0.035	-	J	0.004+0.002	<b>0.006</b>	0.007+0.002	<b>0.009</b>	0.009+0.002	<b>0.011</b>	0.011+0.002	<b>0.013</b>
0.063	A	K	0.004+0.002		0.007+0.002		0.009+0.002		0.011+0.002	
0.094	B	L	0.007+0.005	<b>0.012</b>	0.010+0.005	<b>0.015</b>	0.012+0.005	<b>0.017</b>	0.014+0.005	<b>0.019</b>
0.125	C	M	0.007+0.005		0.010+0.005		0.012+0.005		0.014+0.005	
0.156	D	N	0.007+0.005		0.010+0.005		0.012+0.005		0.014+0.005	
0.187	E	O	0.010+0.005	<b>0.015</b>	0.013+0.005	<b>0.018</b>	0.015+0.005	<b>0.020</b>	0.017+0.005	<b>0.022</b>
0.250	F	P	0.010+0.005		0.013+0.005		0.015+0.005		0.017+0.005	
0.313	G	-	0.015+0.005	<b>0.020</b>	0.018+0.005	<b>0.023</b>	0.020+0.005	<b>0.025</b>	0.022+0.005	<b>0.027</b>
0.375	H	R	0.015+0.005		0.018+0.005		0.020+0.005		0.022+0.005	

Wills Rings® clearance and tolerance correction values (CTCV) for different plating levels for each free height size in Inches. See page 25 for Clearance Tolerance Correction Values in Metric.

Internal pressure  $\text{Ød7} = \text{Øda} + \text{CTCV}$

External pressure  $\text{Ød8} = \text{Ødi} - \text{CTCV}$

**Note:**

Use  $\text{Øda}$  for Wills Rings® O for external pressure

Use  $\text{Ødi}$  for Wills Rings® C for external pressure

For example

MOTOL1200K1HS

This is a 0.187 inch gas-filled Wills Rings® O thin wall seal for a 12.00 inch seal diameter da. It has silver plate at 3 layers, 0.003 inch/0.0035 inch thickness.

The groove diameter is found from  $\text{Ød7} = \text{Øda} + \text{CTCV}$

$$\text{Hence } \text{Ød7} = \text{Øda} + \text{CTCV} \\ = 12.00 + 0.022$$

$$\text{Ød7} = 12.022"$$



Inch Part Number Systems for Wills Rings®

Table 25 Inch Part Number System for Wills Rings® O

Seal Type	Series	Free Height/ Wall Size mm	Seal Diameter	Quality Characteristic Code	Characteristic Number	Seal Material	Coating Material	Treat- ment
M O M Metal O O-Ring profile	S Solid T Gas-filled U Non- pressurized V Pressure vented ID W Pressure vented OD	Standard wall	For small diameter up to 9.999" use	"- Standard Quality "K" X-Ray required "A" Aerospace use	1 = Standard	B Mild steel H Stainless Steel AISI 316L (1.4435) E Stainless Steel AISI 321 (1.4541) M Inconel® 600 L Inconel® 718 O Copper	Q Nickel O Copper I Gold N Indium R Silver 1 layer U Silver 2 layers S Silver 3 layers	5 = Heat treatment to NACE MR0175 (Inconel® 718 only)
		A .063 .014						
		B .094 .018						
		C .125 .020						
		D .156 .025						
		E .187 .032						
		F .250 .040						
		G .313 .050						
		H .375 .060						
		Thin wall						
		J .035 .006						
		K .063 .010						
		L .094 .010						
		M .125 .010						
		N .156 .010						
O .187 .010								
P .250 .020								
R .375 .020								

Notes:

MOV/MOW (Pressure Vented type) seal not available in 0.035" free height. Use MOT type or increase to a 0.063" size instead. Other non-standard plating/coating options are available. Select Quality Characteristic Code K for Thin wall rings.

Example 1

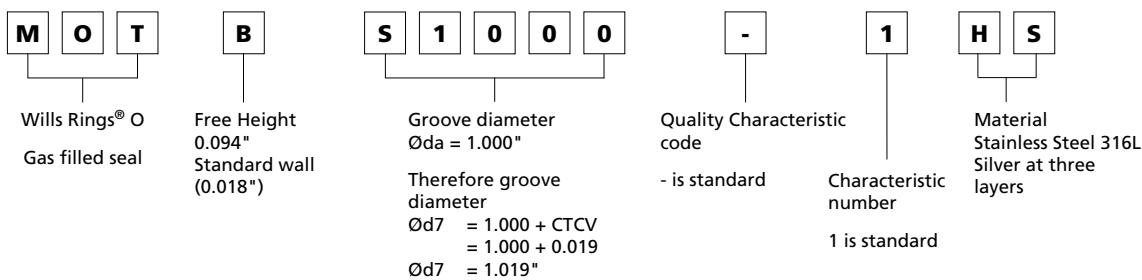

Example 2

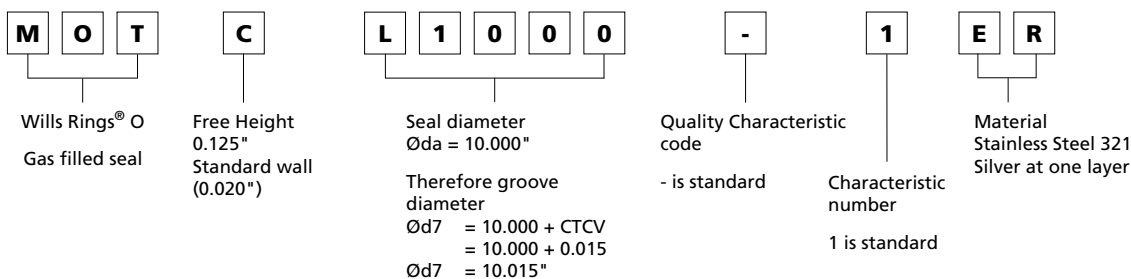

See page 26 for part number system in Metric.





**Table 26 Inch Part Number System for Wills Rings® C**

Seal Type	Series	Free Height/ Wall Size mm	Seal Diameter	Quality Characteristic Code	Characteristic Number	Seal Material	Coating Material	Treatment
M C M Metal C C-Ring profile	X Internal pressure  Y External pressure	Standard wall A .063 .010 B .094 .015 C .125 .020 D .156 .024 E .187 .030  Thin wall K .063 .006 L .094 .010 M .125 .015 N .156 .016 O .187 .020 P .250 .025	For small diameter up to 999.9" use S - - - - this is the seal outside diameter Øda to 3 places  For larger diameter above 10.000" use  L - - - - this is the seal outside diameter Øda to two decimal places  Use outside diameter for internal pressure/ outside sealing  Use inside diameter for external pressure/inside sealing	"-" Standard Quality  "A" Aerospace use	1 = Standard	L Inconel® 718  N Inconel® X750	O Copper  I Gold  N Indium  R Silver One layer  U Silver Two layers  S Silver Three layers	1 = Work hardened  2 = Standard age hardened (short cycle)  3 = Age hardened (long cycle)  4 = Solution annealed and age hardened  5 = Heat treatment to NACE MR0175

**Notes:**

Other non-standard plating/coating options are available. Treatment code 5 for seal material Inconel® 718 only.

**Example 1**

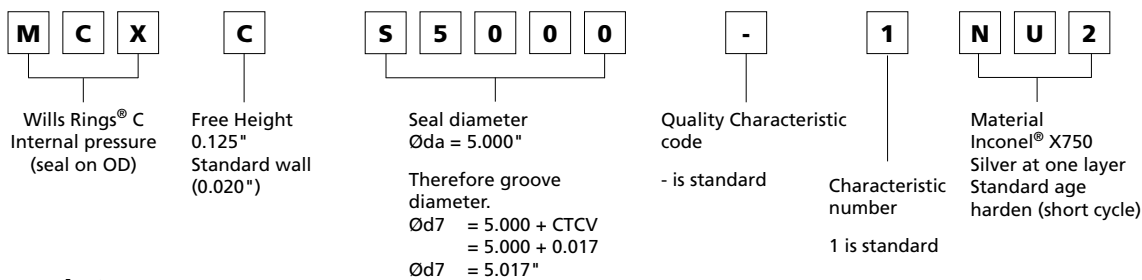

**Example 2**

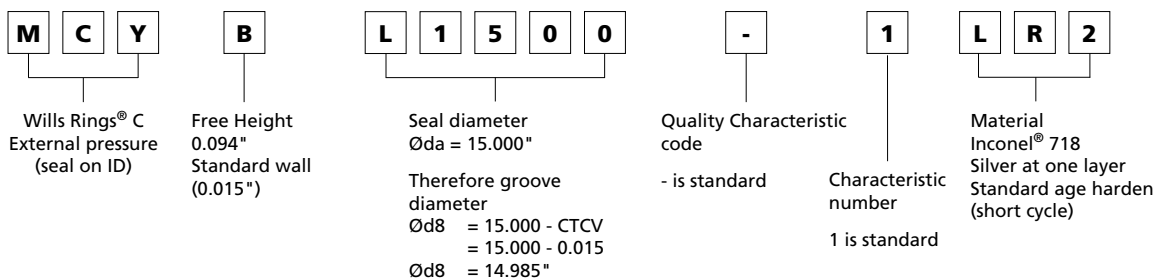

See page 27 for part number system in Metric.



## ■ Quality Criteria

The cost-effective use of seals and bearings is highly influenced by the quality criteria set for production. Seals and bearings manufactured by Trelleborg Sealing Solutions are continuously monitored according to strict quality standards from material acquisition through to delivery.

Our quality policy is consistently controlled by strict procedures and guidelines which are implemented within all strategic areas of the company.

Certification of production facilities is in accordance with international standard EN ISO 9000. Facilities meet the specific requirements for quality control and management of purchasing, production and marketing functions.

All testing of materials and products is performed in accordance with accepted test standards and specifications. Inspection specifications correspond to standards applicable to individual product groups. The tenth digit of our part number defines the quality characteristics of the part. A hyphen indicates compliance with standard quality criteria outlined in this catalog.

Customer-specific requirements are indicated by a different symbol in this position. Customers who require special quality criteria should contact their local Trelleborg Sealing Solutions Marketing Company for assistance. We have experience in meeting all types of customer quality requirements.

## ■ Storage

Seals and bearings are often stored as spare parts for prolonged periods. With a few simple precautions, the shelf life of these products can be considerably lengthened.

Seals and bearings should be stored where they are safe from damage by external influences. Deformation, in particular, should be avoided.

The properties of certain materials may change under the influence of various external factors e.g. heat, moisture, light, oxygen, ozone and as a result of contact with liquid media.

The following guidelines should be observed to maintain the optimum physical and chemical properties of the parts:

### Heat

The ideal temperature for storage is between +5° C / +41° F and +25° C / +77° F. Direct contact with heaters should be avoided.

### Moisture

Parts may be stored dry under normal atmospheric conditions (65 percent rel. moisture ±10).

### Weathering

To protect them against damage, seals and bearings should be kept in the original sealed packaging.





# Conversion Tables

## SI - Basic Units

Measures	Units	Symbol
Length	Meter	m
Mass	Kilogram	kg
Time	Second	s
Electric current	Ampere	A
Temperature	Kelvin	K
Luminous intensity	Candela	cd
Amount of substance	Mol	mol

## Length

	inch	foot	yard	mm	meter
1 inch =		0.0833	0.0278	25.4	0.0254
1 foot =	12		0.333	304.8	0.3048
1 yard =	36	3		914.4	0.9144
1 mm =	0.03937	0.0033	0.00109		0.001
1 meter =	39.37	3.2808	1.0936	1.000	

## Torque

	inch-ounce	inch-pound	foot-pound	kg-meter	Newton-meter
1 inch-ounce =		0.0625	0.0052	$7.2 \times 10^{-4}$	$7.06 \times 10^{-3}$
1 inch-pound =	16		0.0833	$1.152 \times 10^{-2}$	0.1130
1 foot-pound =	192	12		0.1383	1.356
1 kg-metre =	1,388.7	86.796	7.233		9.80665
1 Newton-meter =	141.6	8.850	0.7375	0.1020	

## Area

	inch <sup>2</sup>	foot <sup>2</sup>	yard <sup>2</sup>	mm <sup>2</sup>	m <sup>2</sup>
1 inch <sup>2</sup> =		0.0069	0.00077	645.16	$6.45 \times 10^{-4}$
1 foot <sup>2</sup> =	144		0.111	92,903	0.0929
1 yard <sup>2</sup> =	1,296	9		836,100	0.8361
1 mm <sup>2</sup> =	0.0016	$1.0764 \times 10^{-5}$	$1.196 \times 10^{-6}$		$10^{-6}$
1 m <sup>2</sup> =	1,550	10.764	1.196	106	

## Volume

	inch <sup>3</sup>	US quart	imperial gallon	foot <sup>3</sup>	US gallon	liter
1 inch Superscript 3 =		0.0173	0.0036	0.00058	0.0043	0.0164
1 US quart =	57.75		0.2082	0.0334	0.25	0.9464
1 imp. gallon =	277	4.8		0.1604	1.2	4.546
1 foot <sup>3</sup> =	1,728	29.922	6.23		7.48	28.317
1 US gallon =	231	4	0.8327	0.1337		3.785
1 liter =	61.024	1.0567	0.220	0.0353	0.264	

## Pressure

	inch Hg	psi	atmosphere	torr	mm Hg	bar	MPa	kg/cm <sup>2</sup>
1 inch Hg =		0.491	0.0334	25.4	25.4	0.0339	0.00339	0.0345
1 psi =	2.036		0.0680	51.715	51.715	0.0689	0.00689	0.0703
1 atmosphere =	29.921	14.696		760	760	1.0133	0.10133	1.0332
1 torr =	0.0394	0.0193	0.0013		1	0.0013	0.00013	0.00136
1 mm Hg =	0.0394	0.0193	0.0013	1		0.0013	0.00013	0.00136
1 bar =	29.53	14.504	0.987	749.87	749.87		0.1	1.020
1 MPa =	295.3	145.04	9.869	7498.7	7498.7	10		10.2
1 kg/cm <sup>2</sup> =	28.950	14.22	0.968	735.35	735.35	0.980	0.098	

## Surface Finish R<sub>a</sub>

µm	µin
0.1	4
0.2	8
0.4	16
0.8	32
1.6	64

## Temperature

	°K (Kelvin)	°C	°F
1 °K =		°C + 273.15	(°F - 459.67) 5/9
1 °C =	°K - 273.15		(°F - 32) 5/9
1 °F =	°K 9/5 - 459.67	°C 9/5 + 32	

## Density

	ounce/inch <sup>3</sup>	pound/foot <sup>3</sup>	g/cm <sup>3</sup>
1 ounce/inch <sup>3</sup> =		108	1.73
1 pound/foot <sup>3</sup> =	0.0092		0.016
1 g/cm <sup>3</sup> =	0.578	62.43	

## Force

	Newton (N)	kilopond (kp)	pound force
1 Newton (N) =		0.10197	0.22481
1 kilopond (kp) =	9.80665		2.20463
1 pound force =	4.4482	0.45359	

## Velocity (Speed)

	foot/s	foot/min	mile/hour	meter/s	km/hour
1 foot/s =		60	0.6818	0.3048	1.097
1 ft/min =	0.017		0.0114	0.00508	0.01829
1 mile/hour =	1.4667	88		0.447	1.609
1 meter/s =	3.280	196.848	2.237		3.6
1 km/h =	0.9113	54.68	0.6214	0.278	

## Mass

	ounce	pound	kg
1 ounce =		0.0625	0.0283
1 pound =	16		0.4536
1 kg =	35.274	2.2046	



## Technical Questionnaire

We would be pleased to send you a technical proposal/quotation for your sealing or bearing application upon receipt of this questionnaire. See the back of this catalog or contacts on [www.tss.trelleborg.com](http://www.tss.trelleborg.com) for your local Trelleborg Sealing Solutions Marketing Company. Alternatively submit your request for quotation through our website.

<b>Name:</b>	Date:
Division:	
Company:	<input type="checkbox"/> Technical proposal:
Type of industry:	<input type="checkbox"/> Quotation for          pieces
Address:	Annual usage:
Postal / Zip Code:	
Telephone:	<input type="checkbox"/> Others:
Fax:	

**Please draw the relevant components here, providing dimensions and machining tolerances, or send a copy of your hardware drawing. Also indicate any dimensions that can be changed.**

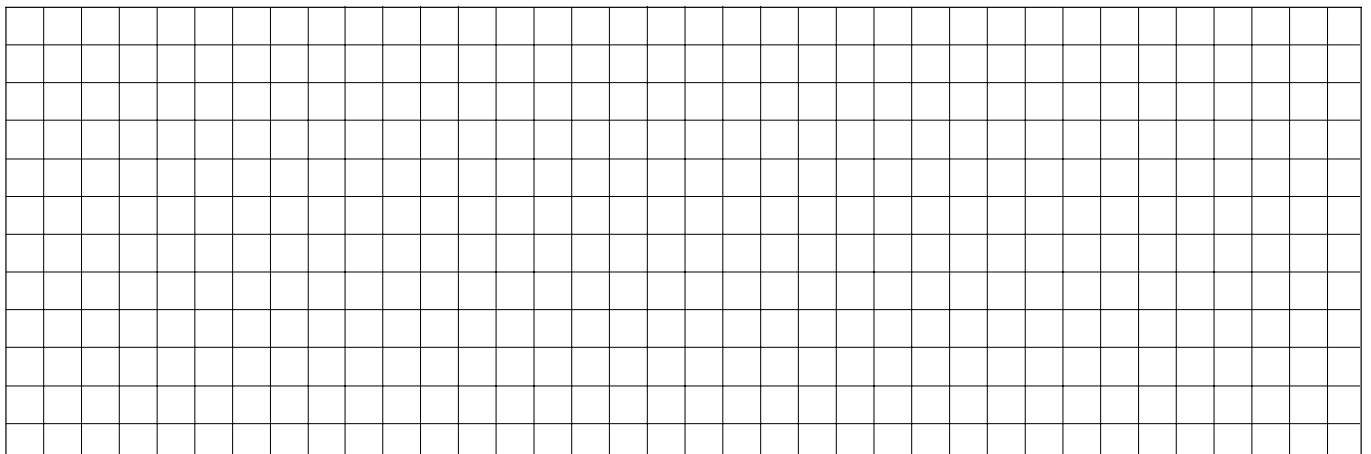

### Service Conditions and Hardware:

<b>Type of component:</b>	Short description of your application or objectives:
Pressure range:	
Operating pressure:	
Temperature range:	
Operating temperature:	
Maximum speed:          Operating speed:	
Media:	
Movement:	
<input type="checkbox"/> oscillating <input type="checkbox"/> reciprocating	
<input type="checkbox"/> rotational <input type="checkbox"/> static	
Number of cycles/frequencies:	
Maximum stroke:	
Material (housing/countersurface):	
Surface finish:	
Service life required:	



## Digital Services

Complex sealing configurations can feature a large number of sealing elements. Trying to illustrate these on a 2D page is difficult and can never properly show their function or characteristics. Trelleborg Sealing Solutions therefore turned to the latest graphic technologies to produce 3D animations of applications and typical sealing solutions for them.

A range of films specific to different industries or products are available to view on the Trelleborg Sealing Solutions website or via YouTube.

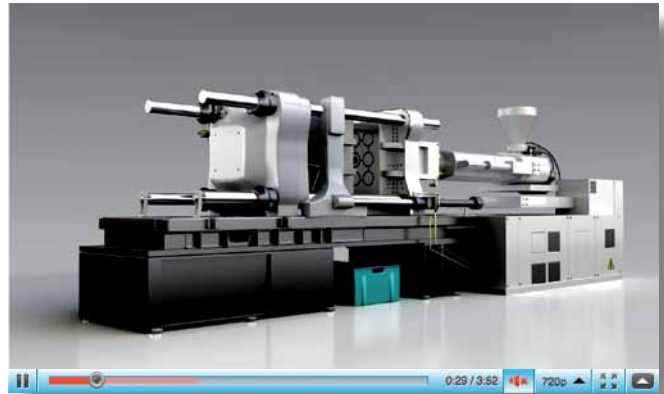

You can now link to our films and animations from

[tss.trelleborg.com/films](http://www.tss.trelleborg.com/films)



or view them on You Tube at

[YouTube.com/trelleborgseals](http://www.YouTube.com/trelleborgseals)







## Digital Services

### Digital tools make life easier

Trelleborg Sealing Solutions has developed a number of digital tools that make the working life of an engineer specifying seals easier.

All these industry-leading tools are available free-of-charge from the Trelleborg Sealing Solutions website at [www.tss.trelleborg.com](http://www.tss.trelleborg.com). To use these advanced services all you have to do is register on the Members Area.

Furthermore, there are a continuously increasing range of innovative engineering apps available for smartphones, both for iOS and Android devices. Just search for "Trelleborg" in the App Store or GooglePlay to find the tools to optimize your daily productivity.



[www.tss.trelleborg.com](http://www.tss.trelleborg.com)

### Sealing Solutions Configurator

The Sealing Solutions Configurator is the first tool of its kind offered by any seal supplier. It allows engineers to identify a proven sealing solution for their specific application in just four easy steps.

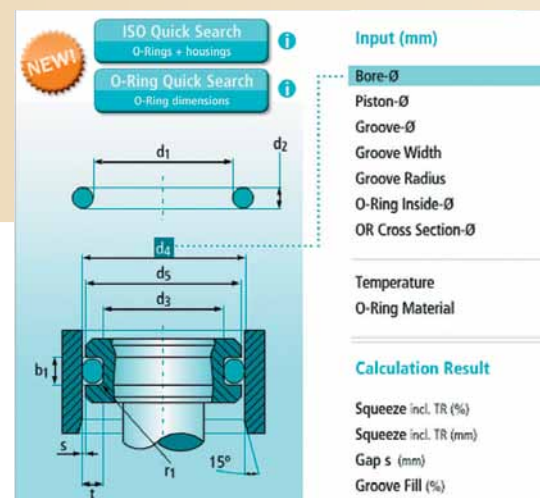
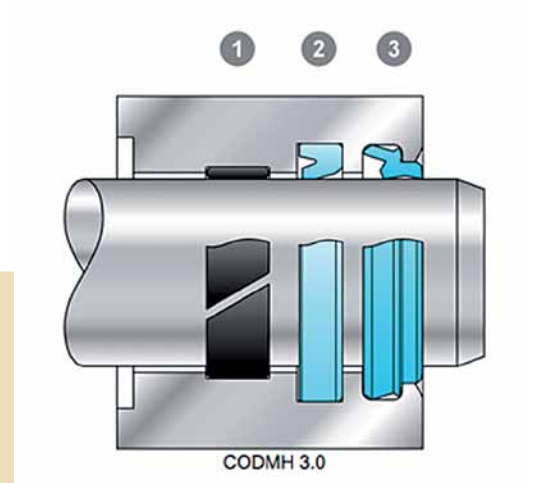

### O-Ring Calculator

An industry-leading tool, the easy to use O-Ring calculator includes a sizing capability, design parameter recommendations and complete measurements. Results and comments may be printed, saved online or filed as a PDF.





## Powerful electronic Catalog

With the powerful electronic catalog you can search through over 100,000 seals by item number or by their properties. Comprehensive and detailed information can be accessed along with an interactive quote facility.



## Versatile CAD service

The CAD download facility provides thousands of drawings from a wide seal range. It gives the option of 2 or 3 dimensional files, in a range of formats to suit most commonly used CAD systems.

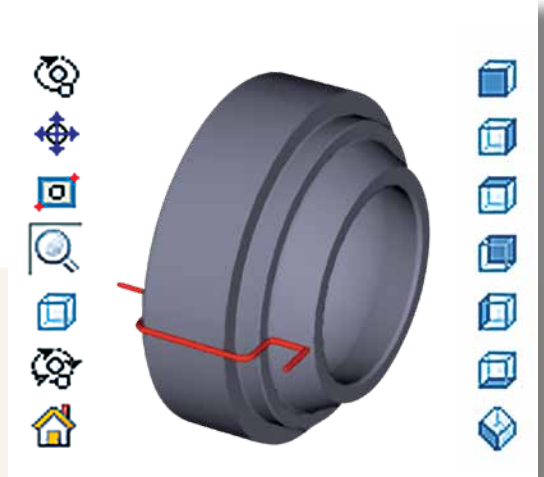

-  Very good suitability
-  Good suitability
-  Limited suitability
-  Unsuitable
-  Insufficient Information



## Materials search and chemical compatibility check

These two programs allow you to find out the compatibility of sealing materials with hundreds of different media and help identify the most suitable material for your application.

## Mobile tools and apps

We understand the needs of engineers on the go. Check out our latest mobile tools and apps, ranging from an O-Ring calculator to unit and hardness converters. Just search for "Trelleborg" in the App Store or Google Play to find the tools to optimize your daily productivity.

**Contact your local marketing company for further information:**

<b>Europe</b>	<b>Telephone</b>	<b>Americas</b>	<b>Telephone</b>
<b>AUSTRIA - Vienna</b> (ALBANIA, BOSNIA AND HERZEGOVINA, MACEDONIA, SERBIA AND MONTENEGRO, SLOVENIA)	+43 (0) 1 406 47 33	<b>AMERICAS - REGIONAL</b>	+1 260 749 9631
<b>BELGIUM - Dion-Valmont</b> (LUXEMBOURG)	+32 (0) 10 22 57 50	<b>BRAZIL - São José dos Campos</b>	+55 12 3932 7600
<b>BULGARIA - Sofia</b> (BELARUS, ROMANIA, TURKEY, UKRAINE)	+359 (0)2 969 95 99	<b>CANADA - Etobicoke, ON</b>	+1 416 213 9444
<b>CROATIA - Zagreb</b>	+385 (0) 1 24 56 387	<b>MEXICO - Mexico City</b>	+52 55 57 19 50 05
<b>CZECH REPUBLIC - Rakovnik</b> (SLOVAKIA)	+420 313 529 111	<b>USA, East - Plymouth Meeting, PA</b>	+1 610 828 3209
<b>DENMARK - Copenhagen</b>	+45 48 22 80 80	<b>USA, Great Lakes - Fort Wayne, IN</b>	+1 260 482 4050
<b>FINLAND - Vantaa</b> (ESTONIA, LATVIA)	+358 (0) 207 12 13 50	<b>USA, Midsouth - Mt. Juliet, TN</b>	+1 615 800 8340
<b>FRANCE - Maisons-Laffitte</b>	+33 (0) 1 30 86 56 00	<b>USA, Midwest - Hanover Park, IL</b>	+1 630 539 5500
<b>GERMANY - Stuttgart</b>	+49 (0) 711 7864 0	<b>USA, Mountain - Broomfield, CO</b>	+1 303 469 1357
<b>GREECE</b>	+41 (0) 21 631 41 11	<b>USA, Northern California - Fresno, CA</b>	+1 559 449 6070
<b>HUNGARY - Budaörs</b>	+36 (06) 23 50 21 21	<b>USA, Northwest - Portland, OR</b>	+1 503 595 6565
<b>ITALY - Livorno</b>	+39 0586 22 6111	<b>USA, South - N. Charleston, SC</b>	+1 843 747 7656
<b>THE NETHERLANDS - Barendrecht</b>	+31 (0) 10 29 22 111	<b>USA, Southwest - Houston, TX</b>	+1 713 461 3495
<b>NORWAY - Oslo</b>	+47 22 64 60 80	<b>USA, West - Torrance, CA</b>	+1 310 371 1025
<b>POLAND - Warsaw</b> (LITHUANIA)	+48 (0) 22 863 30 11		
<b>RUSSIA - Moscow</b>	+7 495 982 39 21	<b>Asia Pacific</b>	<b>Telephone</b>
<b>SPAIN - Madrid</b> (PORTUGAL)	+34 (0) 91 71057 30	<b>ASIA PACIFIC REGIONAL</b>	+65 6 577 1778
<b>SWEDEN - Jönköping</b>	+46 (0) 36 34 15 00	<b>CHINA - Hong Kong</b>	+852 2366 9165
<b>SWITZERLAND - Crissier</b>	+41 (0) 21 631 41 11	<b>CHINA - Shanghai</b>	+86 (0) 21 6145 1830
<b>UNITED KINGDOM - Solihull</b> (EIRE)	+44 (0) 121 744 1221	<b>INDIA - Bangalore</b>	+91 (0) 80 3372 9000
<b>AFRICA REGIONAL</b>	+41 (0) 21 631 41 11	<b>JAPAN - Tokyo</b>	+81 (0) 3 5633 8008
		<b>KOREA - Seoul</b>	+82 (0) 2 761 3471
		<b>MALAYSIA - Kuala Lumpur</b>	+60 (0) 3 9059 6388
		<b>TAIWAN - Taichung</b>	+886 4 2382 8886
		<b>THAILAND - Bangkok</b>	+66 (0) 2732-2861
		<b>SINGAPORE</b>	
		<b>and all other countries in Asia</b>	+65 6 577 1778
		<b>MIDDLE EAST REGIONAL</b> (WITHOUT GCC REGION)	+41 (0) 21 631 41 11
		<b>MIDDLE EAST GCC REGION</b> (BAHRAIN, KUWAIT, OMAN, QATAR, SAUDI ARABIA, UNITED ARAB EMIRATES)	+91 (0) 80 2245 5157

[www.tss.trelleborg.com](http://www.tss.trelleborg.com)

